

**ATL**

**PRODUCT  
SPECIFICATION**

DOC NO.: PS-802848-01  
REV. : F  
SHEET : 1 of 30  
ECN No. : \_\_\_\_\_

# Specification Approval Sheet

**Model: 802848**

**型号: 802848**

Prepared by SLS	Approved by SLS	Approved by CPD	Approved by PRJ	Approved by QA
Grace Liao	Johnson Zhao	Tu Jian	Julius Zhu	ZS Kuang

	Signature	Date
<b>Customer Approval</b>		
	<b>Company Name:</b>	
	<b>Company Stamp:</b>	

--- ATL Confidential ---

**AMENDMENT RECORDS**

<b>Revision</b>	<b>Description</b>	<b>Date</b>	<b>Approval</b>
A	New release	06/11/2008	Daniel Fong
B	Change of handling precautions and guideline	06/18/2008	Daniel Fong
C	Change of wire position and PCM	07/03/2008	Daniel Fong
D	Change of wire position	08/12/2008	Daniel Fong
E	Change of PCM Schematic Drawing	12/30/2008	Daniel Fong
F	Change the MOS transistor; Add the operating window of charging and "Wh" on page 4	10/26/2010	Johnson Zhao

## Content

1. Scope.....	4
2. Part List:.....	4
3. Specification.....	4
4. Performance Criteria.....	5
4.1 Electrical characteristics.....	5
4.2 Mechanical characteristics.....	5
4.3 Climatic Environmental Conditions.....	5
4.4 Safety .....	6
4.5 Visual inspection .....	7
5. Storage and Others .....	7
a) Long Time Storage .....	7
b) Others.....	7
6. Mechanical Drawing (all unit in mm, not in scale).....	8
<b>Handling Precautions and Guideline .....</b>	<b>21</b>
1. Charging.....	22
2. Discharging .....	22
3. Protection Function Requirements for Battery and Host Device .....	24
4. Notice for Designing Battery Pack .....	24
5. Storage.....	25
6. Handling of Cells .....	25
7. User's guideline for safety handling .....	28
8. Others .....	28
Customer Inquiry .....	30

1. Scope

This document describes the Product Specification of the Lithium-ion Polymer (LIP) rechargeable battery 802848 supplied by ATL (Amperex Technology Limited).

2. Model: 802848

3. Specification

No.	Items	Specifications		
1	Charge voltage in 2S	8.4V		
2	Nominal voltage in 2S	7.4V		
3	Minimal capacity (0.2C)	1050mAh @ 0.2C Discharge		
	Normal capacity (0.2C)	1100mAh @ 0.2C Discharge		
4	<b>Rated power for Single cell(Wh)</b>	<b>4.1Wh</b>		
5	<b>Recommended charge condition</b>	<b>Temperature</b>	<b>Charge Current</b>	<b>Charge Voltage</b>
		0°C ~ 14°C	0.2C max	8.00V max
		15°C ~ 28°C	0.5C max	8.40V max
		29°C ~ 45°C	1.0C max	8.40V max
		<0°C, or >45°C	No charging	No charging
6	Standard Charging method	0.5C CC(constant current) charge to 4.2V, then CV(constant voltage 4.2V) charge till charge current decline to ≤ 0.05C		
7	Charging time	Standard charge: 3.0 hours (Ref.) Rapid charge: 2.0 hours (Ref.)		
8	Max. charge current	1.05A		
9	Max. discharge current	1.05A for continuous discharge mode (ATL recommendation)		
10	PCM over discharge cut-off voltage	2.50±0.08V		
11	Operating environment	Charging: 0°C ~ 45°C 85%RH Max Discharging: -20°C ~ 45°C 85%RH Max Non continuous Discharging: 46°C~60°C		
12	Storage environment(applicable for storage less than 3 months)	-20°C~45°C, 65±20%RH		
	Storage environment(applicable for storage more than 3 months)	25±3°C, 65%±20% RH		
13	Pack Weight (2S)	Approx : 45.0 g		
14	Pack Dimension (2cells with PCM and Wire)	Length	48.0 mm Max	
		Width	28.0 mm Max	
		Thickness	Initial	18.0 mm Max
			After 400 cycles	19.5 mm Max

## 4. Performance Criteria

## 4.1 Visual inspection

There shall be no such defect as flaw, crack, and leakage, which may adversely affect commercial value of the cell.

## 4.2 Standard environmental test condition

Unless otherwise specified, all tests stated in this Product Specification are conducted at below conditions:

Temperature :  $25 \pm 3$  °C

Relative Humidity :  $65 \pm 20\%$

## 4.3 Electrical characteristics

No.	Items	Test Method and Condition	Criteria
1	Standard Charge	Charging the cell initially with constant current at 0.5C and then with constant voltage at 8.4V till charge current declines to 0.05C.	Charge Voltage = 8.4V Charge Current = 525mA
2	Rated Capacity of single cell	The capacity means the discharge capacity of the cell, which is measured with discharge current of 0.2C with 3.0V cut-off voltage after the standard charge.	$\geq 1050\text{mAh}$
3	Cycle life of single cell	Continue charge and discharge for 400 Cycles with below condition: Charge: Standard charge ; Discharge: 0.5C; cut off 3.0V; Test Temperature: $25 \pm 3$ °C. The capacity is measured at the end of 400 cycles.	$\geq 80\%$ Recovery capacity
4	Charge (Capacity) Retention	The battery to be charged in accordance with the standard charge at $25 \pm 3$ °C , Then stored the battery at an ambient temperature $25 \pm 3$ °C for 30 days. Measure the capacity after 30 days storage with 0.2C discharge at $25 \pm 3$ °C as retention capacity. Measure capacity with standard charge/discharge as recovery capacity	Retention capacity $> 90\%$
5	Pack Impedance	Pack impedance measured at AC 1KHz after 50% charge.	$\leq 400\text{mohm}$ (In 2S connection)
6	Pack Voltage	As of shipment.	7.2V ~ 7.8 V

#### 4.4 Mechanical characteristics

No.	Items	Test Method and Condition	Criteria
1	Vibration Test	The battery should be charged according to standard charge at 25 +/- 3 °C, and standby 30 minutes at 25 +/- 3 °C. Battery to be load surely to testing machine and vibrated for 90 minutes for each of the three mutually perpendicular planes with total excursion of 1.15mm and with frequency of 10 Hz to 55 Hz. Battery to be discharged, at 25 +/- 3 °C with constant discharge current 0.2C until cut off voltage (3.0V)	No explosion, no fire, no leakage.
2	Shock Test	The cell is to be secured to the testing machine by means of a rigid mount which supports all mounting surfaces of the cell. Each cell shall be subjected to a total of three shocks are to be applied in each of three mutually perpendicular directions shall be tested. Each shock is to be applied in a direction normal to the face of the cell. For each shock the cell is to be accelerated in such a manner that during the initial 3 milliseconds the minimum average acceleration is 75g (where g is the local acceleration due to gravity). The peak acceleration shall be between 125 and 175g. cells shall be tested at a temperature of 20 ± 5 °C (68 ± 9 °F).	

### 4.5 Safety Performance

ATL Battery cell safety is designed according to UL 1642 standard requirement. ATL product's safety performance is conform with UL1642 requirement. UL 1642 certification is up to customer requirement.

No.	Items	Test Method and Condition	Criteria
1	Over discharge / over charge test	The battery should be charged according to standard charge at 25 +/- 3 °C, discharge the battery at constant 0.5C, until battery circuitry terminates discharge or 0V, then charge the battery with 0.5C until battery circuitry terminates charge or 4.3V, for 30 times cycles	No Leakage, no explosion ,no fire
2	Thermal shock	The battery to be tested with 65 °C +/- 2 °C for 48 hours, move to -20 °C within 5 minutes for 24 hrs, standby in ambient temperature 25 °C +/- 3 °C for 24 hrs.	
3	Altitude test (Low pressure)	The battery to be fully charged according to standard charging condition. And then to be store in a vacuum chamber which pressure less than 11.6 KPa (Equivalent to 15000 m from sea level) for 6 hours	
4	Short test	The battery to be fully charged with standard charging condition, and short the positive and negative terminal with wire resistance = 30 mOhm.	No explosion, no fire
5	Free fall test	The battery is fully charged with standard charging condition, and fall from 1m height to concrete ground surface for each panel twice	No Leakage, no explosion, no fire
6	Thermal exposure test	The battery is fully charged with standard charging condition, and store in the oven with 130 °C +/- 2 °C for 10 minutes.	

### 5. Storage and Others

#### 5.1 Long Time Storage

If the Cell is stored for a long time, the cell's storage voltage should be 3.6~3.9V and the cell is to be stored in a condition as No. 4.2. Also, it's recommended to charge the cell every six months.

#### 5.2 Others

Any matters that this specification does not cover should be conferred between the customer and ATL.

### 6. Mechanical Drawing (all unit in mm, not in scale)

#### 6.1 Pack drawing

NOTE: THIS RELEASED DRAWING WAS PRODUCED BY COMPUTER, DO NOT UPDATE MASTER MANUALLY.

DATE: 10/26/2010

**NOTE:**

1. Voltage电压: 7.2~7.8V
2. Initial Impedance电池内阻: 400mΩ
3. Minimum capacity最小容量: 1050mAh
4. Approximal weight大约重量: 45g
5. Max. input voltage最大输入电压: 4.20V
6. Max. charge current最大充电电流: 1050mA
7. Max. discharge current最大放电电流: 1050mA
8. Protection function保护功能
  - 8.1 Overcharging protection voltage 过充保护电压: 4.25±0.025V
  - 8.2 Overcharging recovery voltage 过充恢复电压: 4.05±0.05V
  - 8.3 Overdischarging protection voltage 过放保护电压: 2.50±0.08V

REV	REVISION DESCRIPTION	DATE
F	Change of MOS transistor, add the operating window and "Wh" marking	10/26/2010

Drawn: Gross Lib	Date: 10/26/2010	Date: 10/26/2010	<b>802848 Pack Drawing</b>
Checked: GanSF	Approved: Johnson Zhao	Date: 10/26/2010	SIZE: <b>A4</b>
PROJECT CODE			THIS INFORMATION IS CONFIDENTIAL AND PROPRIETARY TO AMPEREX AND OTHER THAN AMPEREX EMPLOYEES WITHOUT WRITTEN AUTHORIZATION FROM AMPEREX TECHNOLOGY LTD.
Tolerances		Angular	DOC NO
Surface Roughness		Third angle projection	Page
All dimensions are in mm		±0.5	1 OF 1
Break all burrs and sharp edges		DO NOT SCALE	Revision
			F

NO	Component	Code	Description	QTY	Unit	Remark
6	Shrink wrap	PET		2	ea	
5	Wire	AWG26# Black wire		1	ea	
4	Wire	AWG26# Blue wire		1	ea	
3	Wire	AWG26# Red wire		1	ea	
2	PCM	refer to PCM specification		1	ea	
1	Cell	ATL802848, capacity 1050mAh		2	ea	

19.5 max after cycle life



### 6.2 PCM/PCB specification

#### 6.2.1 Electrical specification (PCM for each single cell)

No.	Items	Specifications
1	Max input voltage	DC 12V
2	Max charging current	1.5A
3	Max discharging current	1.5A
4	PCM Operating temperature range	-20~65°C
5	PCM Storage temperature:	-45~85°C
6	Over-charging protection	4.25±0.025V
7	Over-charging recovery	4.05±0.05V
8	Over-discharging protection	2.50±0.08V
9	Discharge Current Protection	2.5A ~ 5.5A
10	Operation Current	MAX 15.0uA
11	Initial Impedance	≤ 100mΩ

#### 6.2.2 Part list (Refer to 6.2.4)

Item	Part Name	Qty	Spec	Remark
1	Control IC	1	S-8232NIFT-T2-G	U1
2	MOSFET	1	ECH8601M	U2
3	Resistance	4	0402/1KΩ/±5%	R1-R4
4	NTC	1	0603/10KΩ±1%/B=3435	NTC
5	Capacitor	4	0402/0.1μF/+80%-20%	C1-C4
6	PCB(Main Board)	1	802848-A/Four layers/Immersion Gold	
7	PCB(Relay Board)	1	802848T-A/Double layers/Immersion Gold	
8	Ni plate	6	3303(3.0*3.0*0.30)	
9	Resistance	1	0402/10KΩ/±1%	R5

#### 6.2.3 Pin explanation

##### 1) PCM Pin explanation for Cell A (Main board)

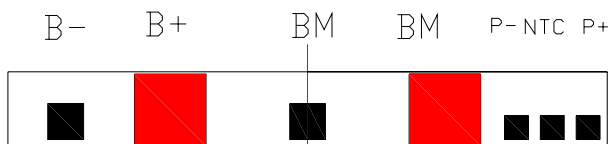

symbol	explanation	symbol	explanation
P+	Battery output/charging positive pole	B+	Cell A positive pole
P-	Battery output/charging negative pole	B-	Cell B negative pole
BM	Cell A negative pole and Cell B positive pole		
NTC	NTC pole		

### 2) PCB with Fuse Pin explanation for Cell B (Relay Board)

#### a. Front side

B- B+ B+ B-



symbol	explanation
B+	Cell B positive pole
B-	Cell B negative pole

#### b. Back side

B+ B+

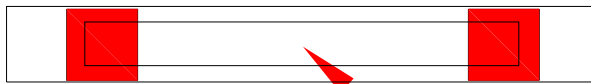

thermal fuse

symbol	explanation
B+	Fuse pole

### 6.2.4 PCM Schematic Drawing

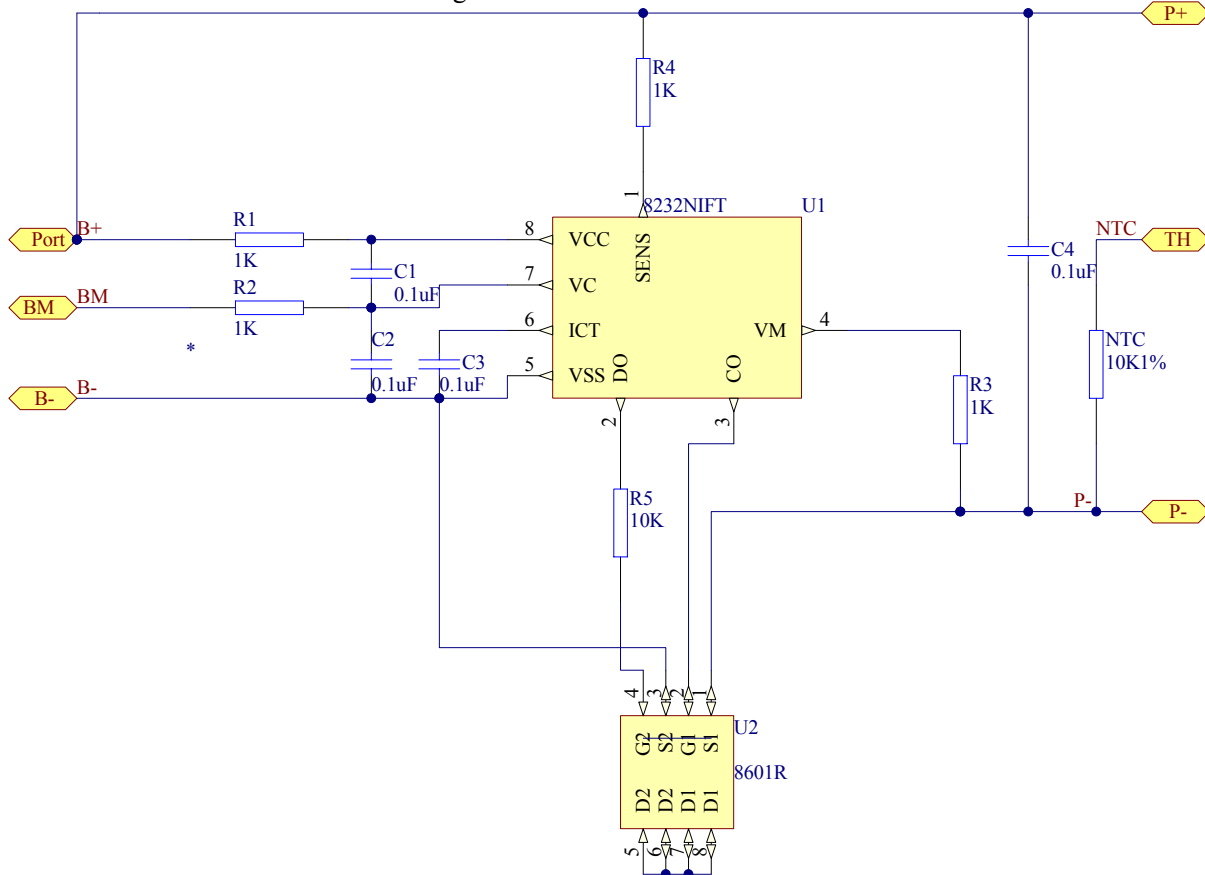

### 6.2.5 Drawing (unit: mm)

#### 1) PCM for Cell A (Main board)

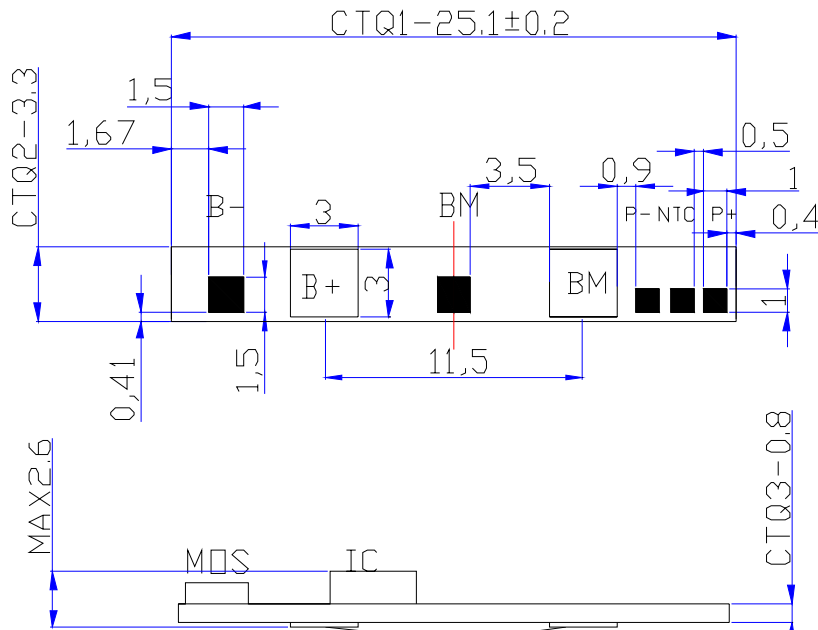

NOTE:

Unmarked Tolerance:  $\pm 0.1$

#### 2) PCB with Fuse for Cell B (Relay Board)

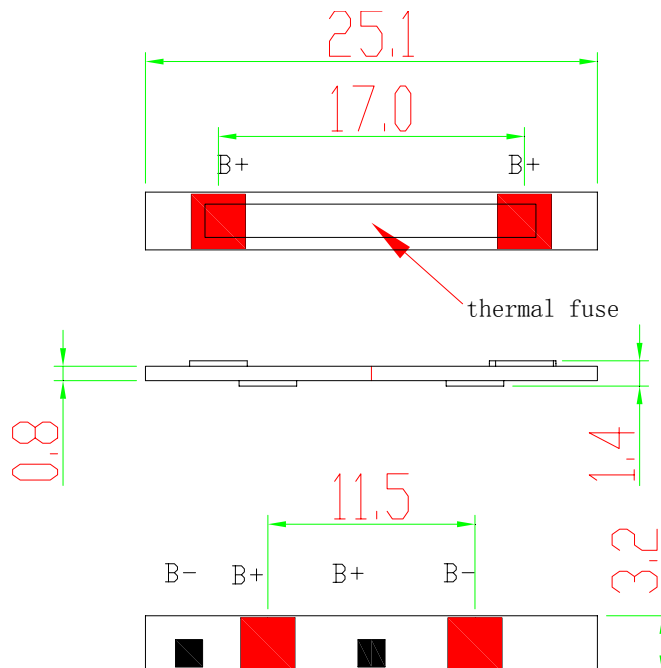

NOTE:

Unmarked Tolerance:  $\pm 0.1$

# ATL

## PRODUCT SPECIFICATION

DOC NO.: PS-802848-01  
REV. : F  
SHEET : 12 of 30

### 6.3 Thermal fuse specification

ATL  
\_\_\_\_\_

Issue No. : 151YP00005132  
Date of Issue : October 04.2005  
Classification :  New  Changed

## PRODUCT SPECIFICATION FOR APPROVAL

Product Description : Thermal -Links / Thermal Cutoffs  
Product Part Number : EYP4MU092XU

Country of Origin : JAPAN  
Applications :

\*If you approve this specification, please fill in and sign the below and return 1 copy to us.

Approval No	:	
Approval Date	:	
Executed by	:	
		_____
		(signature)
Title	:	
Dept.	:	

Circuit Components Business Unit  
Panasonic Electronic Devices Co., Ltd.

401 Sadamasa-cho,  
Fukui City 910-8502 Japan

Phone : +81-776-56-8034  
Fax : +81-776-56-3114

Prepared by : Engineering Section

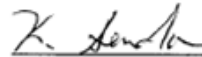
Contact Person :  
Signature   
Name(Print)  
Title :

Authorized by :  
Signature   
Name(Print)  
Title : Manager of Engineering

# Panasonic

# ATL

## PRODUCT SPECIFICATION

DOC NO.: PS-802848-01  
REV. : F  
SHEET : 13 of 30

Classification	SPECIFICATION	Code No. YP-E-150
Subject	THERMAL CUTOFFS / THERMAL LINKS ( MS series, ML series, MT series, MU series, TP series )	1 of 7

### PRECAUTIONS IN HANDLING (Application instructions)

#### 1. Precautions in design

1) Use the TCO within their specified temperature and electrical ratings..

① Use the TCO under an ambient temperature of not more than the maximum operating temperature specified in the individual specification. Using the TCO under a higher temperature than the maximum operating temperature may cause premature opening or opening delay.

\* When TCO is continuously used at the temperature close to the functioning temperature, the TCO may operate while being used.

\* When the TCO is continuously used at the temperature higher than the maximum operation temperature, the TCO may be degraded and may not operate normally at the specified temperature..

② The holding temperature (Th) is defined as the highest temperature at which the TCO is activated continuously at the rated current for 168 hours. The TCO can not be used over 168 hours exceeding the holding temperature.

③ Equipment shall be so designed that its overshoot does not exceed the maximum temperature limit(Tm) after the TCO operates.

④ If the TCO is activated by voltage higher than the rated voltage or current higher than the rated current, the TCO produces excessive heat, resulting in premature opening. The arc generated at this condition of operation will result in an abnormality of appearance (crack on body and/or peeled insulating film) and insufficient insulation..

\* When TCO is operated at abnormal status of mode while the rated voltage and/or the rated current being exceeded, it may not cut off the circuit.

⑤ In case that transient overload might be applied, repeat the tests under the worst conditions assumed for decision before determining whether or not TCO is used.

⑥ The TCO cannot be used as a current sensitive fuse

2) To bring out fully the performances of TCO, a suitable TCO for equipment must be selected. Verification tests to select shall be made yourself every model.

① Tests should be repeated for the finished equipment to confirm that the TCO does operate as expected.

② To maximize the thermal response of TCO, bring both the body and the terminals as close to the heat source as possible and put into mounting location where the TCO is evenly heated. If there is large difference between the temperature transferred to the body and the temperature transferred to the terminals, TCO might operate faulty and cause in arcing and insulation deterioration.

3) TCO body and terminals must be properly fixed when the TCO is mounted in the equipment. It may cause breaking of thermal element and/or terminals, or damages of the TCO body, or other failure when the body or terminals is not properly connected. Avoid a transport under the condition with a connection only a single side of terminal and the equipment as it might cause breaking of thermal element and/or terminals, or damages of the TCO body, or other failure due to the vibration or mechanical stress on the transportation.

4) When TCO is mounted in the equipment, terminals must be aligned with the body. If TCO body and terminals are mutually mounted askew, it might cause breaking of thermal element and/or terminals. Also after assembling TCO in the equipment, avoid pulling, bending, pushing stress and twisting stress in the TCO body and terminals in order not to cause breaking of thermal element and/or terminals, or damages of the TCO body.

5) Avoid vibration or other stress in the finished equipment. They may cause breaking of thermal element and/or terminals and damage of TCO body by the vibration or some stress even if the TCO in the equipment is kept at temperatures below its Maximum operating temperature.

Remarks / Revision

Date enforced:

April 1, 2005

Panasonic Electronic Devices Co., Ltd..

Manager

Checked

Prepared

*A. W.*

*K. Sak*

*K. Sak*

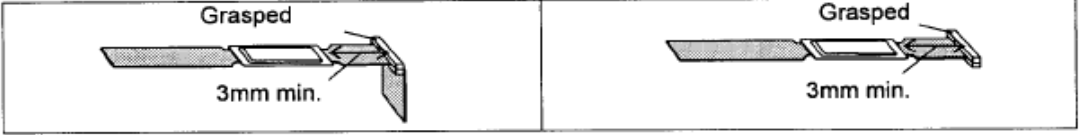
Classification	SPECIFICATION		Code No. YP-E-150
Subject	THERMAL CUTOFFS / THERMAL LINKS ( MS series, ML series, MT series, MU series, TP series )		2 of 7
<p>6) When sealing the TCO with resin, select the resin that does not corrode the body and/or terminals. When sealing the overall TCO with resin, test repeatedly on the finished equipment in order to confirm if TCO is damaged by the expansion and shrinkage of the resin itself, by the curing temperature, and if the sealed TCO operate normally. Especially when TCO is assembled by hot-melt casting and so on, keep the working condition so that the temperature of TCO body may not reach up to its Operating temperature minus 15 degrees Celsius and the working time at over its Holding temperature may not take longer than ten minutes.</p> <p>7) When immersing equipment on which the TCO is mounted in varnish or solvent and drying it, repeat the test to check whether or not the varnish or solvent used dissolves the coating of the TCO or causes damage, such as cracks, before performing the treatment</p> <p>8) TCO does not take the use under the following special environments into consideration. Do not use under the following environments.</p> <ul style="list-style-type: none"> <li>① In liquids such as water, oil, chemical and/or organic solvent.</li> <li>② Under direct sunlight, and/or outdoor and/or dusty atmospheres.</li> <li>③ In place where water condensation occurs.             <ul style="list-style-type: none"> <li>* Use in the following environments may affect the performance of the TCO; Verify performance and reliability etc. before production use.                 <ul style="list-style-type: none"> <li>a. In places full of corrosive gases such as sea breeze, Cl<sub>2</sub>, H<sub>2</sub>S, NH<sub>3</sub>, SO<sub>2</sub> and/or NO<sub>2</sub>.</li> <li>b. In environment with high static electricity and/or strong electromagnetic waves.</li> </ul> </li> <li>* Do not use TCO in aerospace equipment, atomic energy equipment, military weapon, life saving equipment, etc.</li> </ul> </li> </ul> <p>2. Precautions in handling</p> <p>The body of TCO is composed of resinous film, and please do not be pressured TCO with instruments. Moreover, the terminals are thin and have the edges, and please carry out suitable handling not injured. (Using of a glove, tweezers, etc. is recommended)</p> <p>1) Forming and cutting</p> <ul style="list-style-type: none"> <li>① Terminals are to be bent or cut at least 3 mm away from the TCO body to avoid damaging the TCO body. shall not be grasped with any tools or holders. Terminals of thin type TCO are to be grasped before they are bent. (See Fig.1)</li> <li>② It is recommended that experimental assembly be made by production personnel to verify that manufacturing procedures does not exceed neither a pulling forces of 5N nor a pushing forces of 5N on the terminals (pulling forces of 10N and pushing forces of 5N in case of MU/MT series), and that manufacturing procedures does not induce excessive twisting between both terminals or between terminal and body.</li> <li>③ The terminals shall not be nicked, fractured or burned. The body must not be damaged, burned or overheated.</li> </ul> <div style="text-align: center;">  <p>Fig.1</p> </div> <p>2) Welding</p> <ul style="list-style-type: none"> <li>① The terminals are to be certainly clamped not to damage TCO at least 3mm away from the body. Improper connections may cause damage to the body or other parts and may result in nuisance tripping of the devices due to the generation of excessive heat at a faulty high resistance junction.</li> <li>② It is recommended that the preliminary test to determine proper welding conditions is made in order not to make the heat of welding influence TCO, for example, function the TCO or narrow the fusible alloy, etc, and in order that the welding method, like a resistance welding, laser welding, ultrasonic welding and so on, does not damage to TCO.</li> <li>③ When re-welding, cool off TCO in the room conditions for at least 30 seconds.</li> </ul>			
Remarks / Revision			
Date enforced:	Panasonic Electronic Devices Co., Ltd.		
April 1, 2005			

Classification	<b>SPECIFICATION</b>	Code No. YP-E-150
Subject	<b>THERMAL CUTOFFS / THERMAL LINKS</b> ( MS series, ML series, MT series, MU series, TP series )	3 of 7
<p>④ When TCO is heated by welding, be careful not to pull, push or twist the TCO terminals.          ⑤ If water or solvent is used for cleaning, check and confirm reliability of the agent.</p> <p>3) Do not make soldering. If TCO is to be soldered, please inquire about soldering of our engineering department.</p> <p>4) The use of sufficiently flexible, appropriate free length and proper size wire shall be used for splice connection. Connection including connectors used for splicing shall be of the low resistance type, and they shall be made mechanically secure.</p> <p>5) In case that TCO is fixed to other component or units by some material like taping, the force to the body and/or terminal should not exceeded 3N.</p> <p>6) Do not repair TCO. For replacement, install the same part number of TCO in the same way exactly.</p> <p>3. Matters to be attended to from the viewpoint of quality control</p> <p>1) Measurement of resistance between terminals and checking of the internal status with X-rays are effective means to confirm the status of TCO on delivery and at mounting in the equipment.</p> <p>2) It is necessary to confirm normal operation of TCO with the trial pieces and the equipment of the initial production lot set at normal condition and at abnormal condition.</p> <p>4. Storage method</p> <p>1) Store TCO in packing cases or in polyethylene bags within the temperature of -10°C to +40°C and relative humidity of 30% to 75%. Store them at the location where no rapid change of temperature or humidity, or no direct sunlight is applied. The location must also be free from vibration or shock or the like.</p> <p>2) Avoid the storage in places containing corrosive gases such as sea breeze, Cl<sub>2</sub>, H<sub>2</sub>S, NH<sub>3</sub>, SO<sub>2</sub> and/or NO<sub>2</sub>.</p> <p>3) The period of guarantee for performance such as weldability is for one year after our delivery; and this condition applies only in the case where the storage method specified in above has been followed.</p> <p>5. Law and Regulations</p> <p>1) No ozone-depleting substances subjected to regulations under the Montreal Protocol are used in our manufacturing processes, including in the manufacture of this product.</p> <p>2) All the materials used in this product exist in chemical substances recognized under "Laws on examination of chemical substances and regulations of manufacturing and others."</p> <p>3) None of the materials used in this product contain the designated incombustible bromic substances, PBBOs or PBBs.</p> <p>4) Please contact us to obtain a notice as to whether this product has passed inspection under review criteria primarily based on Foreign Exchange and Foreign Trade Control Law and appended table in the Export Control Law.</p> <p>6. Notice</p> <p>1) Please return to us a sheet of the specifications after you accept them and sign on the cover page. Unless returned to us beyond three months from the date of issue, we should consider that you have accepted them.</p> <p>2) In time to modify this specification, when we receive your acceptance under mutual confirmation based on your review, we understand that you accept the revised specification and consider the former specifications to be not effective.</p>		
Remarks / Revision		
Date enforced:	Panasonic Electronic Devices Co., Ltd.	
April 1, 2005		

Classification	SPECIFICATION	Code No. YP-E-150
Subject		4 of 7
<b>THERMAL CUTOFFS / THERMAL LINKS</b> ( MS series, ML series, MT series, MU series, TP series )		

### 1. General

#### 1.1 Scope

This specification is applicable to TCO which are shipped for your company. Details or exceptions which should be applicable to the particular items are specified in the Individual Specifications. If there are any differences between this specification and the Individual Specifications, the Individual Specifications should have the priority.

#### 1.2 Scope of Quality Assurance

TCO is designed for safety by sensing overheating of electric and electronic equipment and cutting off circuits to prevent fires or smokes. So, check and confirm the "PRECAUTIONS IN HANDLING" (see page 1 to 3) before use. The Scope of Quality Assurance is restricted to the TCO unit itself, as specified in this specification. We have not responsibility to failures such as abnormality of the equipment like, generated from using, installing or handling beyond this Scope of Quality Assurance.

### 2. Explanation of part number

Part number of TCO is indicated as follows.

EYP 2 ML 098 UP  
 (1) (2) (3) (4) (5)

- (1) "Product code" is indicated by code.
- (2) "Rated current" is indicated by code. (See Table.1)
- (3) "Series" is indicated by code. (See Table. 2)
- (4) "Rated functioning temperature" is indicated by code.  
(See attached Individual Specifications.)
- (5) "DC resistance", "Processing of terminals" and "Pb free" is indicated by code.  
(See attached Individual Specifications. in details)

Table.1: Rated current

Code	Rated current
2	2A
4	4A

Table2.Series, Rated voltage

Code	Series	Rated voltage
MS	MS series	50V
ML	ML series	50V
MT	MT series	50V
MU	MU series	50V
TP	TP series	32V

### 3. Rating

Ratings are specified in the Individual Specifications.

### 4. Approved Safety Standard

Please confirm the Individual Specifications in details.

### 5. Constructions and marking

#### 5.1 Constructions

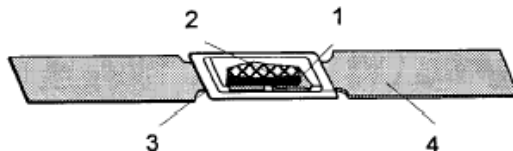

- 1. Fusible alloy
- 2. Special resin (Flux)
- 3. Insulating part
- 4. Terminal (Ni)

Remarks / Revision

Date enforced:

April 1, 2005

Panasonic Electronic Devices Co., Ltd.



Classification	SPECIFICATION	Code No. YP-E-150
Subject	THERMAL CUTOFFS / THERMAL LINKS ( MS series, ML series, MT series, MU series, TP series )	5 of 7

### 5.2 Dimensions

Dimensions are specified in the Individual Specifications.

### 5.3 Marking

All the markings shall be legible at regular handling.

### 5.4 Appearance

There shall be no visible damage such as destruction of the insulating part, remarkable scratch, or sharp bending of the terminals, etc.

## 6. Performance tests

Unless otherwise specified, all the performance tests shall be made under the following conditions.

Temperature: 25°C±10°C  
 Relative humidity: 45% to 75%  
 Air pressure: 86kPa to 106kPa

### 6.1 Calibration verification test (Functioning temperature test)

TCO shall be placed in an air oven and exposed at a temperature approximately 20°C below the rated functioning temperature for 15minutes to 30 minutes. The temperature shall then be increased with a rate of rise between 0.5°C/min to 1°C/min until the TCO functions (A detecting current shall be 10mA or less).

The TCO shall function within the range specified in the Individual Specifications. If the result is doubtful, the TCO shall be tested in an oil bath as same method as above.

### 6.2 DC resistance

DC resistance shall be measured between both terminals including the body at the points of 20mm or the distance specified in the Individual Specifications (if total length of TCO is less than 20mm) at the current specified in the Individual Specifications (See Fig.1). DC resistance shall be within the range specified in the Individual Specifications.

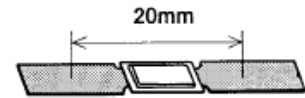

Fig.1

### 6.3 Surface temperature increment (MS series only)

TCO shall be applied at rated current in the windless ambient temperature of 25°C±5°C. After stabilizing, the surface temperature of the central position of TCO shall be measured by thermocouple (See Fig.2).

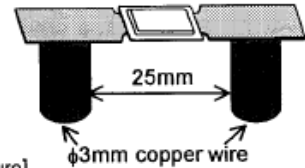

Fig.2

$$[\text{Surface temperature increment}] = [\text{Surface temperature on TCO}] - [\text{ambient temperature}]$$

### 6.4 Insulation resistance

- (1) After the test in clause 6.1, insulation resistance is to be measured between the terminals at DC100V. Insulation resistance shall be within the range specified in the Individual Specifications.
- (2) Insulation resistance is to be measured between the metal foil coiled round the body and terminals at DC100V. Insulation resistance shall be within the range specified in the Individual Specifications.

Remarks / Revision

Date enforced:

April 1, 2005

Panasonic Electronic Devices Co., Ltd.

Classification	<b>SPECIFICATION</b>	Code No. YP-E-150
Subject	<b>THERMAL CUTOFFS / THERMAL LINKS ( MS series, ML series, MT series, MU series, TP series )</b>	6 of 7
<p><b>6.5 Dielectric voltage withstand</b></p> <p>(1) After the test in clause 6.4(1), the TCO shall be capable of withstanding without breakdown while it shall be subjected to an AC voltage application specified in the Individual Specifications between the both terminals for 1 minute (increased voltage: 100V/s, detecting current: 1mA).</p> <p>(2) TCO shall be capable of withstanding without breakdown while it shall be subjected to an AC voltage application specified in the Individual Specifications between the metal foil coiled round the body and terminals for 1 minute (increased voltage ratio: 100V/s, detecting current: 1mA).</p> <p><b>6.6 Terminal pull strength</b></p> <p>One terminal is to be supported and the pulling force specified in the Individual Specifications is applied to other terminal for 10 seconds. There shall be no break of fusible alloy and/or terminals. The TCO is then followed by the test in clause 6.1.</p> <p><b>6.7 Terminal bend strength</b></p> <p>The body and a part of terminal are held so that a terminal is turned in the vertical plane through an angle of 90 degrees for 2 seconds to 3 seconds at 3mm apart from the edge of body and then returned to the original position at the same speed. Next the body of TCO is turned in opposite direction through an angle of 90 degrees and then returned to the original. There shall be no break of lead. The TCO is then followed by the test in clause 6.1.</p> <p><b>6.8 Crush</b></p> <p>A fixed board is to be put on the TCO, and the force specified in the Individual Specifications shall be applied to the TCO for 10 seconds. TCO shall be free from damage. The TCO is then followed by the test in clause 6.1. The functioning temperature shall be within the range specified in the Individual Specifications.</p> <p><b>6.9 Humidity</b></p> <p>TCO shall be placed in the test chamber maintained at a temperature 40°C±3°C and a relative humidity 90% to 95% for 500 hours. The TCO is then followed by the test in clause 6.1. The functioning temperature shall be within the range specified in the Individual Specifications.</p> <p><b>6.10 High temperature exposure</b></p> <p>TCO shall be placed in an air oven maintained at [maximum operating temperature] (+0°C, -3°C) for 1000h. The TCO shall not function throughout the test. The TCO is then followed by the test in clause 6.1. The functioning temperature shall be within the range specified in the Individual Specifications.</p> <p><b>6.11 Load life</b></p> <p>TCO shall be placed in an air oven maintained at [maximum operating temperature] (+0°C, -3°C)°C and then subjected to a rated current specified in the Individual Specifications for 1000 hours. The TCO shall not function throughout the test. The TCO is then followed by the test in clause 6.1. The functioning temperature shall be within the range specified in the Individual Specifications.</p> <p><b>6.12 Temperature cycling</b></p> <p>TCO is subjected to continuous 100cycles for 30 minutes at each temperature specified in the Individual Specifications. The TCO shall not function throughout the test. There shall be no remarkable abnormality. The TCO is then followed by the test in clause 6.1. The functioning temperature shall be within the range specified in the Individual Specifications.</p>		
Remarks / Revision		
Date enforced:	Panasonic Electronic Devices Co., Ltd.	
April 1, 2005		



CLASSIFICATION	<b>INDIVIDUAL SPECIFICATION</b>	Code No. YP-E-743R2
Subject	THERMAL-LINKS / THERMAL CUTOFFS <b>EYP4MU092XU</b> (Approved type No. of safety standards is MU092X)	1 of 1

### Dimensions and Marking

#### Dimensions

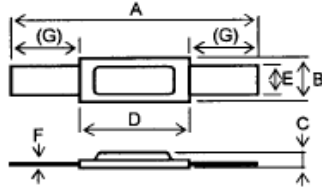

Note: All dimensions in millimeters.

#### Marking



A	B	C	D
26.5±0.5	4.5±0.4	1.0±0.15	11.0 (+0.6, -0.4)
E	F	(G)	
3.0±0.2	0.15±0.02	(7.7)	

### Ratings

Item	Rating
Electrical rating	DC50V/4A
Rated functioning temperature	92°C
Maximum operating temperature	55°C
Holding temperature	55°C
Maximum temperature limit	150°C
Operating temperature	89(+3,-4)°C

#### Rated functioning temperature (Tf)

The temperature at which a TCO changes its state of conductivity to open circuit with detection current as the only load.

The temperature in the oven is then to be increased at a rated of 0.25°C to 0.5°C per minute until all TCO open.

Functioning temperature of each TCO shall not differ by more than plus 0°C and minus 10°C from the Tf.

#### Holding temperature (Th)

The maximum temperature at which a TCO can be maintained while conducting rated current for 168 hours which will not cause a change in state of conductivity to open circuit.

#### Maximum temperature Limit (Tm)

The maximum temperature at which a TCO can maintains its mechanical and electrical properties without closing again for 10 minutes after a TCO has changed its state of conductivity.

### Performance specifications

Test item	No.	Method and condition	Specification
Calibration verification test (Functioning temperature test)	6.1	Increased temperature rate: 1°C/min	89(+3,-4)°C
DC resistance	6.2	Less than 1A within 20mm	7mΩmax.
Surface temperature increment	6.3	Rated current 4A	10K(deg) max.
Insulation resistance	6.4	(1)Between the both terminals at DC100V (2)Between the body and terminals at DC100V	100MΩ or more than 100MΩ
Dielectric voltage-withstand	6.5	(1)Between the terminals at AC100V for 1min (2)Between the body and terminals at AC1100V for 1min	Withstanding at the normal conditions
Terminal pull strength	6.6	10N, 10s	89°C(+3,-4)°C
Terminal bend strength	6.7	90°, 1time	89°C(+3,-4)°C
Crush	6.8	30N, 10s	89°C(+3,-4)°C
Humidity	6.9	500h at 40°C and 90% to 95%	89°C±5°C
High temperature exposure	6.10	1000h at 55°C (no load)	89°C±5°C
Load life	6.11	1000h, 4A at 55°C	89°C±5°C
Temperature cycling	6.12	100cycles at -20°C and 55°C	89°C±5°C

Approved Standards (Type, File No.)	UL	VDE			
	E60271	481106-1171-0009			
Date enforced	Panasonic Electronic Devices Co., Ltd..		Manager	Checked	Prepared
April 1, 2005			<i>[Signature]</i>	<i>[Signature]</i>	<i>[Signature]</i>

**Handling Precautions  
For LIP (Lithium-Ion Polymer) Rechargeable Batteries****Foreword**

This document of Handling Precautions and Guideline for LIP Rechargeable Batteries shall be applied to the battery cells manufactured by ATL (Amperex Technology Limited).

**Statement (1):**

Customers are requested to contact ATL in advance, if and when the customer needs other applications or operating conditions than those described in this document. Additional experimentation may be required to verify performance and abuse under such conditions.

**Statement (2):**

ATL will take no responsibility for any accident when the cell is used under other conditions than those described in this Document.

**Statement (3):**

ATL will inform, in a written form, customers of improvement(s) regarding proper usage and handling of cells, if it is deemed necessary.

**Statement (4):**

During designation of host device or battery pack, it's better for customers to get ATL involve to review the battery installation and protection scheme. This is very helpful to battery application.

**1. Charge****1.1 Charge Current:**

Charge current should be less than the maximum value specified in the Product Specification. Charging with higher current than recommended value may cause damage to cells' electrical, mechanical, and performance and could lead to heat generation or leakage.

**1.2 Charge Voltage:**

Charging shall be done by voltage less than that specified in the Product Specification (4.2V/cell). Charging beyond 4.25V, which is the absolute maximum voltage, must be strictly prohibited. The charger and protection circuit of battery pack shall be designed to comply with this condition. It is very dangerous that charging with higher voltage than the maximum value and may cause damage to the cell electrical, mechanical performance and could lead to heat generation or leakage.

**1.3 Charge Temperature:**

Batteries shall be charged at 10°C~45°C environment temperature specified in the Product Specification. In case of environment temperature is lower than 10°C, charge shall be with a little current (recommend 0.1C). If the environment temperature is lower than 0°C, charge shall be prohibited.

**1.4 Prohibition of Charge to 0V Cells:**

Generally, it is prohibited to charge 0V cells. In case of the capacity is less than 500mAh, this prohibition could be relaxed. But the cell must be pre-charged with a little current (recommend 0.01C) until the voltage reach 3.0V.

**1.5 Prohibition of Reverse Charge:**

Reverse charge is prohibited. Cells shall be connected correctly. The polarity has to be confirmed before wiring. In case of the cell is connected improperly, the cell cannot be charged. Simultaneously, the reverse charging may cause damage to the cell which may lead to degradation of cell performance and damage the cell, and could cause heat generation or leakage.

**2. Discharge****2.1 Discharge Current:**

The cell shall be discharged at less than the maximum discharge current specified in the Product Specification. High discharging current may reduce the discharge capacity significantly or cause over-heat.

**2.2 Discharge Temperature:**

Cells shall be discharged at -10°C~55 °C environment temperature specified in the Product Specification.

**2.3 Over-discharge:**

It should be noted that cells would be at an over-discharged status due to self-discharge characteristics in case they were not used for a long time. In order to prevent over-discharging, cells shall be charged periodically to maintain the voltage between 3.6V and 3.9V. Over-discharging may cause the loss of cell performance, characteristics, or battery functions.

**3. Protection Function Requirements for Battery and Host Device:**

Battery pack and host device shall be designed with below protection function to make sure cells at a recommended usage conditions:

- a) Over-charge protection;
- b) Over-discharge protection;
- c) Over current protection;
- d) Over-heat protection;
- e) Short circuit protection.

**3.1 Overcharge Protection:**

Overcharge protection function shall be triggered and stop charging if any one of the cells of a battery pack reaches 4.25V.

The host device and battery pack shall be designed to indefinitely withstand the maximum voltage from the adapter, under a single fault condition, to prevent a cascading failure through the system to the battery pack and/or cell.

**3.2 Over-discharge Protection:**

When the voltage of any cell in a battery pack is lower than 2.3V, over-discharge protection function shall work and stop discharging to prevent the cells from over-discharge. It is recommended that the dissipation current of PCM shall be less than 5uA. The voltage of each cell in a battery pack shall be monitored and current shall be controlled by the PCM all the time.

**3.3 Over Current Protection:**

In case of charge current is over the limitation specified in the Product Specification, the charging must be cut off. The battery pack shall have at least one over current protection circuitry or devices designed to meet the specification to avoid the cell is charged with greater current than the Product Specification. The host device shall be designed to indefinitely withstand the maximum current from the adapter, under a single fault condition, to prevent a cascading failure through the system to the battery pack and/or cell.

**3.4 The Requirements to the Components of Protection Circuit:**

Cells, components, and materials used in the battery pack shall meet the minimum and maximum temperature requirements with adequate margin. Protection circuit components (excluding thermal devices designed to activate at specific temperatures) shall be rated for a minimum operating range of  $-25^{\circ}\text{C}$  to  $+85^{\circ}\text{C}$ .

**3.5 Over Temperature Protection:**

The battery pack or host device shall contain at least one thermal protection device or mechanism independent of internal cell devices or mechanisms. For a thermistor type temperature protection circuit, all packs of the same model shall have the same voltage to temperature translation (acceptable tolerance no more than  $\pm 10\%$ ), with consideration for any temperature lag over time.

During charge and discharge, the temperature of cells shall be monitored. When temperature limitations are exceeded, action shall be taken to mitigate hazards. Action should include shutdown, or disabling of charging, or other protective action. The action may be taken by the battery pack and/or host.

**3.6 The Limitation of Charge Time:**

In order to prevent abnormal cells or battery packs are charged for a long time, charge time shall be limited according to the Product Specification. When time limitations are exceeded, action shall be taken by the host device or the battery pack to shutdown, or disable the charging.

**3.7 Pre-charge Function:**

The system shall not initiate normal charging if the battery voltage is below the over-discharge protection voltage defined in the Product Specification. In this case, the system may support a pre-charging function to bring the battery voltage above the required threshold. The recommended pre-charge procedure is as below:

The cell battery pack charging shall start with a low current (0.01C~0.1C ATL Recommended for 15 - 30 minutes before rapid charging starts. The rapid charging shall be started after the (individual) cell voltage has been reached above 3V that can be determined with the use of an appropriate timer for pre-charging. In case the (individual) cell voltage does not rise to 3V within the pre-charging time, then the charger shall have functions to stop further charging and display the cell/pack is at abnormal state.

### 3.8 The Other Requirements to Main Device Designation:

In case of fault happened in host device, it shall not disable the protection features inside the battery pack(s). The charging system, or any part of the host device, shall not disable or override the protection features inside the battery pack(s)

## 4. Notice for Designing Battery Pack

### 4.1 Pack Design

- 4.1.1 Battery pack should have sufficient strength to make sure the cell(s) inside is protected from mechanical shock..
- 4.1.2 Battery needs to be properly secured and fixed inside the battery component
- 4.1.3 No sharp edge components should be inside the pack containing the battery.
- 4.1.4 Allowances shall be made for cell and battery pack dimensional tolerance and changes throughout the product lifetime.

### 4.2 Battery should not be directly contacted with metal parts from any assembly components

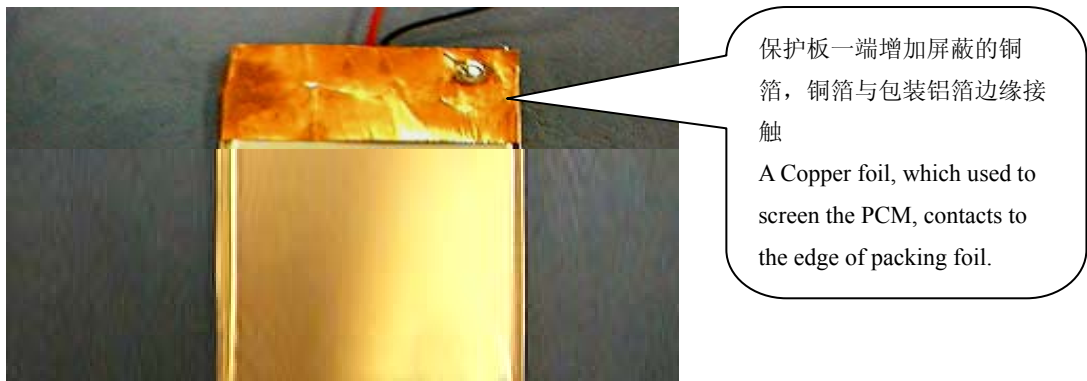

(图二)

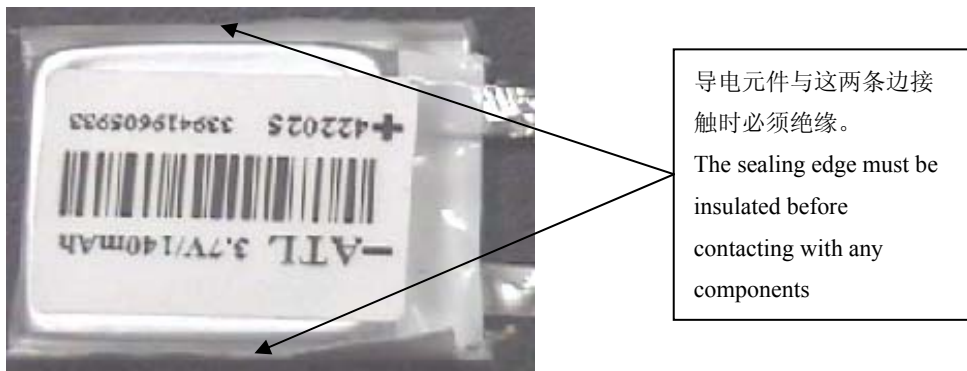



#### 4.3 Tab Connection

4.3.1 Ultrasonic welding or spot welding is recommended to connect cell(s) with PCM or other parts.

4.3.2 If use manual solder method to connect tab with PCM, below notice is very important to ensure cell performance:

- a. The solder iron should be temperature controlled and ESD safe
- b. Soldering temperature should not exceed 350°C
- c. Soldering time should not be longer than 3s. Rework times should not exceed 4 times. Keep battery tab cold down before next time soldering.
- d. Directly heat cell body is strictly prohibited. Battery may be damaged by heat above approx. 100°C

#### 4.4 Cell Fixing

4.4.1 The cell(s) should be fixed to the battery pack or host device on its largest surface area.

4.4.2 No cell movement in the battery pack should be allowed.

4.4.3 Prevention of short circuit in a battery pack or host device.

4.4.4 Enough insulation layers between wiring and the cells shall be used to maintain extra protection. The battery pack or host device shall be structured with no any potential short circuit, which may cause generation of smoke or firing.

#### 5. Storage

The cell shall be stored at the environmental condition of -20°C~ 45°C and 60+/-20% RH.

If the cell has to be storied for a long time (Over 3 months), the environmental condition should be:

Temperature: 25 ± 3°C

Humidity: 65 ± 20%RH

The voltage for a long time storage shall be 3.6V~3.9V range.

#### 6. Handling of Cells

Since cells are packed in soft material, to ensure its better performance, careful handling is very important.



##### 6.1 Soft Aluminium Foil

The soft aluminum packing foil may be damaged by sharp matter such as Ni-tabs, pins and needles or other tooling and fixtures.

- a) Don't strike cells with any sharp matter
- b) Trim your nail or wear gloves before taking cells
- c) Clean worktable to make sure no any sharp particle
- d) Battery cannot be used as mechanical buffer



### 6.2 Top Sealing Edge

Sealing edge on the top of cells is very flimsy and easy to be delaminated. Don't bend or fold this area



### 6.3 Side Sealing Edge

The side sealing edge has been folded and fixed in cell forming processes and passed hermetic test. The Aluminum foil may brake by re-folding time after time. Don't open and refold this edge



### 6.4 Tabs:

The cell tabs are easy to be broken especially for Aluminum tab. Don't bend the tabs.



### 6.5 Mechanical Shock:

Don't Fall, shock, bend cell body.



### 6.6 Short

Short terminals of cells is strictly prohibited, it may damage cells, even result in accident.



**7. User's handling precautions:**

7.1 The following information, or equivalent statements, shall be made available to the user through one or more of the following means, as appropriate: printed on the label for the battery, printed on the label for host device, printed in the owner's manual, or posted in a help file or Internet website:

- Do not disassemble or open, crush, bend or deform, puncture, or shred;
- Do not modify or remanufacture, attempt to insert foreign objects into the battery, immerse or expose to water or other liquids, or expose to fire, explosion, or other hazard.
- Only use the battery for the system for which it was specified.
- Only use the battery with a charging system that has been qualified with the system per standard. Use of an unqualified battery or charger may present a risk of fire, explosion, leakage, or other hazard.
- Do not short circuit a battery or allow metallic or conductive objects to contact the battery terminals.
- Replace the battery only with another battery that has been qualified with the system per standard. Use of an unqualified battery may present a risk of fire, explosion, leakage, or other hazard.
- Don't keep a battery at rest for a long time (over 6 months). Accident may happen when re-charging a battery which has a rest for a long time.
- Promptly dispose of used batteries in accordance with local regulations.
- Battery usage by children should be supervised.
- Avoid dropping the phone or battery. If the phone or battery is dropped, especially on a hard surface, and the user suspects damage, take it to a service center for inspection.
- Improper battery use may result in a fire, explosion, or other hazard.
- In the event of a battery leak, do not allow the liquid to come in contact with the skin or eyes. If contact has been made, wash the affected area with large amounts of water and seek medical advice.
- Seek medical advice immediately if a battery has been swallowed.
- Communicate the appropriate steps to be taken if a hazard occurs.

7.2 The following indications, notifications, and dialog/messages, at the system level, or an equivalent statement, may be displayed along with recommended actions as appropriate:

- Abnormal battery temperature alert.
- Abnormal host device and/or battery dc input voltage alert.
- Abnormal current draw alert.
- Battery communication fail/time-out alert.
- Incompatible battery alert.
- Alert for other malfunctions that may lead to hazards.

**8. Others**

8.1 Prohibition of reusing and reworking on battery which removed from device

8.2 Prohibition of Disassembly

8.2.1 Never disassemble cells. The disassembling may generate internal short circuit in the cell, which may cause swelling, firing, or other problems.

8.2.2 Electrolyte is harmful. LIP battery should not have liquid from electrolyte flowing, but in case the electrolyte come into contact with the skin, or eyes, physicians shall flush the electrolyte immediately with fresh water and medical advice is to be sought.

8.3 Never incinerate nor dispose the cells in fire. These may cause firing of the cells, which is very dangerous and is prohibited.

8.4 The cells shall never be soaked with liquids such as water, seawater, drinks such as soft drinks, juices, coffee or others.

8.5 The battery replacement shall be done only by either cells supplier or device supplier and never be done by the user.

8.6 Prohibition of use of damaged cells

The cells might be damaged during shipping by shock. If any abnormal features of the cells are found such as damages in a plastic envelop of the cell, deformation of the cell package, smelling of an electrolyte, an electrolyte leakage and others, the cells shall never be used any more. The Cells with a smell of the electrolyte or a leakage shall be placed away from fire to avoid firing.

**9. Warranty**

9.1 Unless specified otherwise, ATL warrants to the customer that the products (excluding third party products and software), will be free from defects in materials and workmanship affecting normal use for a period of one year from shipping date (“standard warranty”).

9.2 This standard warranty does not cover damage, fault, failure or malfunction due to external causes, including accident, abuse, misuse, problems with electrical power, servicing not authorized by ATL.

### Customer Inquiry

Model: 802848

Version: F

The customer is requested to write down your information and contact ATL in advance, if and when the customer needs applications or operating conditions other than those described in this document. ATL could design and build such products according to your special request.

	Special Request	Criteria
1		
2		
3		
4		
5		

Company Name: \_\_\_\_\_ Signature: \_\_\_\_\_ Date: \_\_\_\_\_