

# INTRODUCTION TO ROBOTICS LESSON PLAN

## USING THE EV3 SOFTWARE DESKTOP VERSION

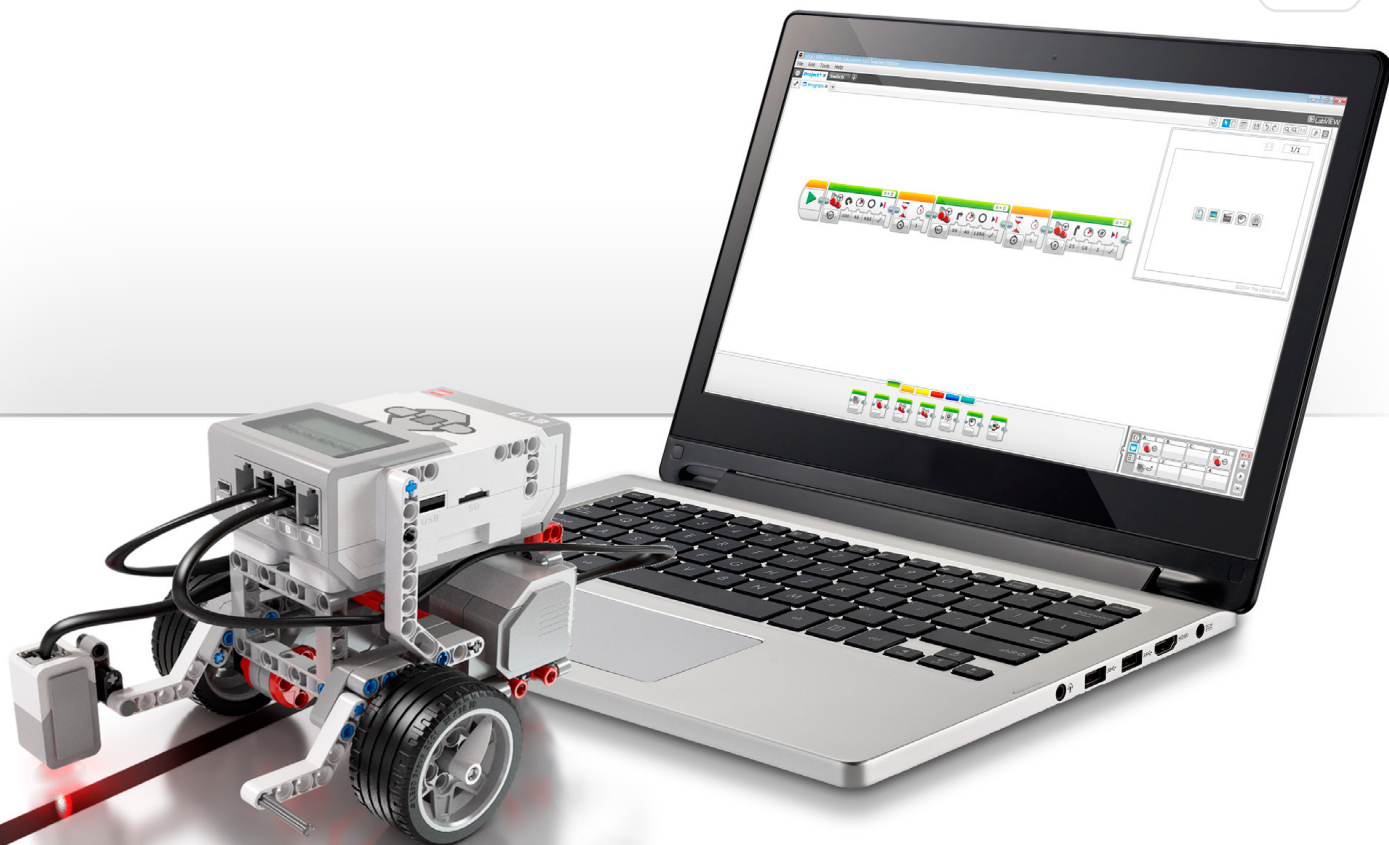

## Table of Contents

Introduction to Robotics Lesson Plan .....	3
Lesson 1 - Building and Setup .....	9
Lesson 2 - Curved Move .....	11
Lesson 3 - Move Object .....	14
Lesson 4 - Stop at Object .....	16
Lesson 5 - Stop at Angle .....	18
Lesson 6 - Stop at Line .....	21
Lesson 7 - Switch .....	24
Master Challenge 1 - The Turntable Challenge .....	26
Master Challenge 2 - The LEGO® Factory Robot Challenge .....	28
Design Brief Challenges .....	30
Relevant Standards .....	31
Class Assessment Record .....	35
Appendix A .....	36
Appendix B .....	37
Appendix C .....	38
Appendix D .....	39

## Introduction to Robotics Lesson Plan

This Lesson Plan provides educators with step-by-step instructions for how to use the LEGO® MINDSTORMS® Education EV3 Software, with classroom-based lessons. Each lesson and challenge will give teachers the help they need to prepare, run, and assess the class. It is up to the teacher to select which, as well as how many of the provided extra tasks and challenges will be used in the Robotics course.

Within the program, teachers have the option to start the course by either focusing on some of the Design Brief Challenges, or by having students complete the tasks after a more structured start, using the tutorials provided.

### Who Is It For?

Robot Educator is a valuable tool for anyone who wishes to learn how to use LEGO MINDSTORMS Education EV3.

### What Is It For?

The coursework for the LEGO MINDSTORMS Education EV3 Software focuses primarily on engineering, technology, and computer science. However, it also provides an opportunity to integrate cross-curricular activities, such as science and mathematics, when students complete the challenges.

The engaging and motivating nature of the EV3 Software enables students to construct and program, as well as provide them with the scope to experiment, without prior knowledge or experience around programming or building.

The featured Lesson Plans enable educators to take a step-by-step approach to the course or, if required, to use a more open-ended approach.

The Lesson Plans are invaluable for equipping teachers with what they need to teach students how to use LEGO MINDSTORMS Education EV3 within a classroom setting. They also serve as a learning guide for the EV3 programming language and the hardware included within the set. The intuitive programming interface, combined with the supporting material, will enable students to make a quick and easy transition into robotics within a STEM context. Teachers who are already familiar with the EV3 Software will find fresh inspiration within the educational package to further the building and programming skills of their students.

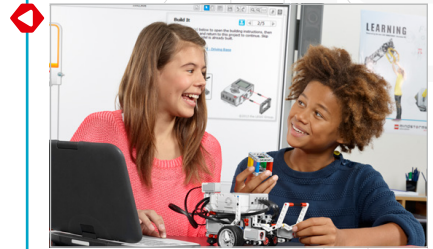

### What Is in the Lesson Plan PDF?

- Step-by-step help on using six of the Robot Educator tutorials
- A range of ideas for lesson-specific challenges
- Two Master Challenges that provide solid opportunities for students to use EV3 in a STEM context
- Four open-ended Design Brief Challenges
- References to relevant subject standards
- Suggestions on how to assess student learning
- A class assessment record

The LEGO® MINDSTORMS® Education EV3 Software, Lessons, and Challenges are designed for use with the 45544 LEGO MINDSTORMS Education EV3 Core Set.



## Classroom Management Tips

### How Much Time Do I Need?

The time taken to complete each of the tutorials as well as the suggested activities in the Lesson Plan depends on a number of factors, including the level of complexity, the age of the students, and the students' experience with LEGO® MINDSTORMS® and the concepts covered in the relevant lesson. The following estimates are therefore based on the time it would take an average student with no prior experience with LEGO MINDSTORMS to complete the following tasks:

Category	Estimated Completion Time Including Building (in minutes)
Tutorial	45-90
Tutorial and Lesson Challenge	90-135
Master Challenge 1	90-180
Master Challenge 2	90-270
Design Brief Challenge	90-270

Based on the estimates listed above, it should be possible for your students to complete the first tutorial within a 45-minute class period.

### Additional Materials

To complete the Lesson Plan, the following additional materials will be required: different-colored sticky tape or paper (at least black, blue, gray, and one other color), large sheets of paper, objects of different shapes and sizes, protractors, measuring tapes (minimum length 1 meter), and markers.

Challenge-Based Assessment

The LEGO® MINDSTORMS® Education EV3 Software concept includes several ways of assessing students' work. The hands-on Challenge approach, which provides a simple method of observing a robot's ability or failure to complete a task, is an effective way of challenging a student's problem-solving skills and integrating student and teacher assessment tools. When students have difficulty completing a challenge using their robot, they are motivated to improve their design or program in order to see something that they have built themselves succeed; this is a self-reinforcing process.

In the "Test It" phase of the tutorials, students can record notes on the Canvas by adding a Comment Box from the menu. This process encourages students to reflect on the connection between the programming blocks and robot behavior.

The "Modify It" tasks included in the tutorials help consolidate learning by asking students to make changes in the sample program to fulfill a given task.

Lesson Challenges provided for teachers in the Lesson Plan enable students to show that they can apply the skills gained via the tutorials. Each Lesson Plan includes a discussion section which gives guidance on what kinds of questions to ask students, along with model answers. In the Design Brief Challenges, you can choose an approach that, compared to the step-by-step tutorials, is more open-ended. This allows you to assess students' innovation and collaboration skills.

By using the Challenge-based assessment approach, students can apply their STEM learning in an authentic context and show what they have learned.

Where Can I Find the Assessment Materials?

Assessment materials are provided for all seven Lessons and for the two Master Challenges.

You can find the Introduction to Robotics class assessment record on page 35. The Introduction to Robotics rubrics are provided as a separate PDF in the Lesson Plan Category in the Teacher's Support section.

What Learning Goals Are Assessed?

On the Introduction to Robotics rubrics PDF, students can evaluate their project work according to the learning goals. Each rubric includes four levels: Bronze, Silver, Gold and Platinum. The intention is to help students reflect on what they have done well in relation to the learning goals and what they might do better. Students could mark an X to indicate the appropriate rubric level. You can also use the rubrics for your own evaluation of the students' work, marking your own X in the appropriate column, and adding optional comments in the Notes column.

If a more formative assessment approach is required, you can record grades on the class assessment record provided on page 35. The students can retain the Introduction to Robotics rubrics as a record of their progress.

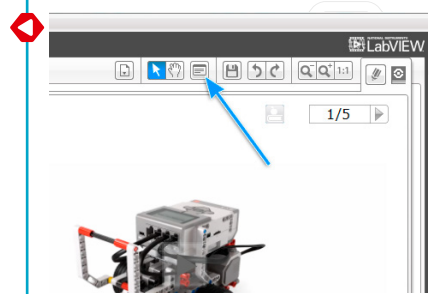

Lesson 1 – Building and Setup table with columns: Goals, Bronze, Silver, Gold, Platinum, Notes. Each goal column contains a LEGO MINDSTORMS EV3 icon and a brief description of the objective.

Introduction to Robotics Class Assessment Record table with columns for student names and rows for tracking progress across various learning goals.

### Student Documentation

When documenting, students will reflect on and consolidate what they have just learned, as well as how to use appropriate language to communicate it. You can ask students to:

- Write full descriptions of their working processes
- Add images and videos of their robot in action
- Take screenshots from the EV3 Software
- Share their unique project with other students

Guide the students on how to use the Edit Mode in the Content Editor when documenting what they have learned after each Lesson.

### Before Starting the First Lesson

If you have never worked with LEGO® MINDSTORMS® Education EV3 before, you should ensure the following:

1. Each computer has a preinstalled version of the LEGO MINDSTORMS Education EV3 Software.
2. Each EV3 Brick has the latest firmware and is fully charged.
3. Before connecting computers and EV3 Bricks via Bluetooth in the classroom, we recommend renaming each EV3 Brick. This can be done in two ways:
  - a. Update the name via the desktop EV3 Software using a USB cable.
  - b. Update to firmware V1.07E or later and change the name via the EV3 Brick Settings Area (see the User Guide for more help).
4. Check out the Quick Start Videos in the Lobby.

You may want the students to understand the names and functions of the different elements in the brick set. Discuss the naming and basic functionality of the key hardware components and establish a set of brick management rules. Please refer to the User Guide for the Core Set Elements List.

#### Firmware Update

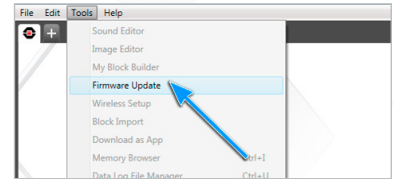



## Lesson 1 – Building and Setup

### Objective

After completing this lesson, students will be able to build the Driving Base, connect the computer to the EV3 Brick, and download and run programs that control the robot's behavior.

### Duration

2 to 3 x 45 mins.

### Preparation

Understand the process of connecting a computer to the EV3 Brick. Watch the **Programming** Quick Start Video for guidance. Distribute one EV3 Core Set per two to three students. Optional: cardboard, textiles, and other materials for personalizing the robots.

### Procedure

1. Students build the Robot Educator Driving Base using the Building Instructions booklet (included with the 45544 Core Set) or the software-integrated Building Instructions available via the Driving Base link on page two of each tutorial.

**Note:** Ensure that all students get to build part of the model during the activity.

**Optional:** An effective way of allowing students to take ownership of their robot is to have them personalize it using additional LEGO® elements and other materials. By doing this, they can turn their robot into a puppy, elephant, or even a fantasy creature.

2. As a class, go through the process of connecting the computer with the EV3 Brick and running the first program, or direct the students to the **Programming** Quick Start Video, which will help them to connect the devices themselves.
3. Students use the programming software to make simple programs that:
  - a. Make their robot play a sound that is appropriate to their creature

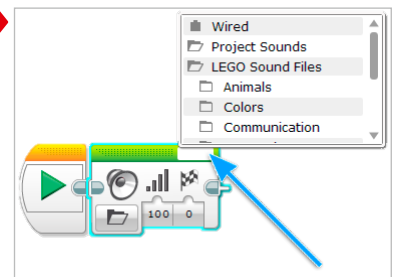
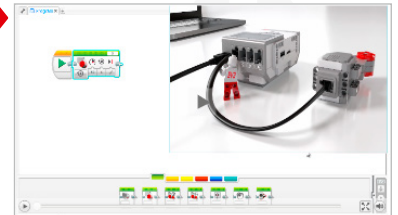
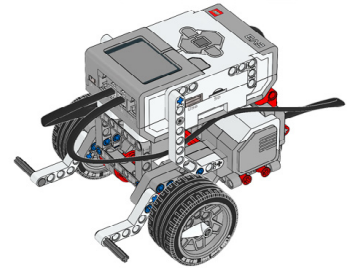
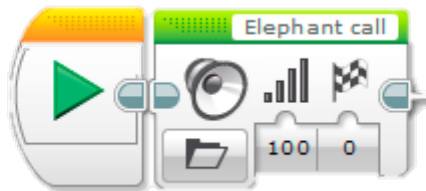

b. Make their robot display an image or their own text in the EV3 Brick Display



c. Make their robot flash the Brick Status Light.

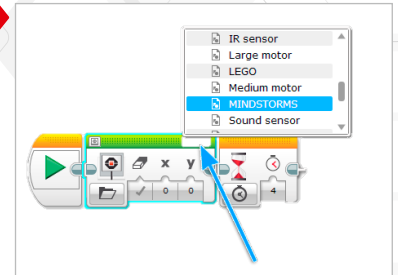
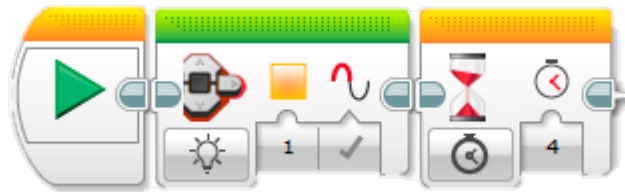

### Discussion Questions

**Robot Behavior:** What problems did you encounter when constructing the Driving Base?

- *Might have used the wrong components in a step and had to go back and change the model, or had difficulty finding parts, especially the smaller ones.*

**Program Flow:** What did you have to do to change either the Sound or Brick Display image?

- *Click the top right hand corner of the programming block and select a file.*

**Discovery:** What did you find out when you connected the EV3 Brick to the computer?

- *The EV3 Software asked for a firmware update.*
- *You must insert the USB cable the correct way up.*

### Assessment

During the lesson, students can interact with the Introduction to Robotics rubrics, using peer or self-assessment, and can record their progress by marking the box that best reflects their level of work. Help your students to improve by writing a comment for each of them in the Notes column during the lesson cycle.

## Lesson 2 – Curved Move

### Objective

After completing this lesson, students will be able to navigate their robot through an obstacle course. By selecting the correct programming blocks and setting their parameters, students will know how and when to use point turns, single-motor turns, and curved turns.

### Duration

2 to 3 x 45 mins.

### Preparation

For task 5b you will need rubber bands to allow students to attach a pen to their robot. For task 5c you will need to prepare an obstacle course on the floor. You can use a large sheet of paper and markers, or place sticky tape on the floor (see illustration below).

### Procedure

1. Introduce students to the Lobby of the LEGO® MINDSTORMS® Education EV3 Software. Students need to know where to find the Robot Educator tutorials and how to open them. Demonstrate the flow of one tutorial to ensure that students know their way around the tutorials in combination with the Programming Canvas and Hardware Page (see also the Quick Start Videos).
2. Students complete and test the **Curved Move** tutorial, which introduces the Move Steering Block.
3. In the “Test It” phase, the students will see a sample program to copy. Ensure that each group takes the time to describe the robot’s behavior in their own words, while running the program. This encourages the students to reflect on what they see and how it relates to the programming blocks. Students can record notes on the Canvas by adding a Comment Box from the menu.

The following sample program is provided for the students:

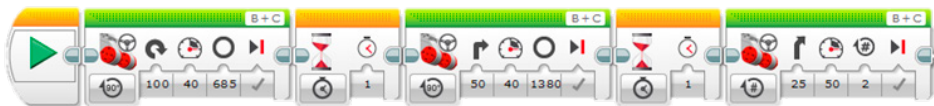

Example of a robot behavior description:

The robot performs a point turn, then a single-motor turn, and lastly, a curved turn. Each action is separated by a pause, which allows the robot to settle before executing the next action.

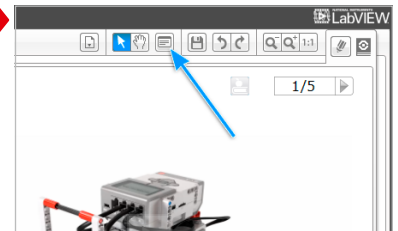
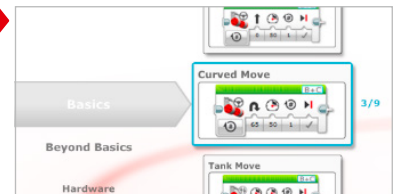
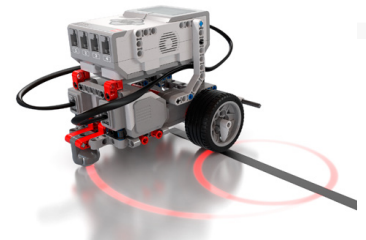

4. Students solve the “Modify It” task, which challenges them to add three Move Steering Blocks to their program in order to make the robot drive backwards, following the same path back to the starting position.

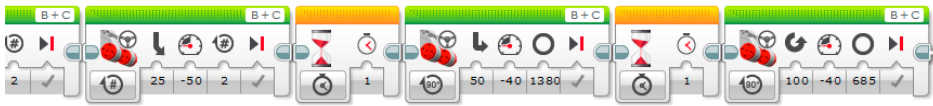

5. Lesson Challenge Ideas:

- Program the robot to trace out a figure eight, the first letter of your name, or another letter or number.
- Attach a pen to the robot and program it to draw a cloverleaf, heart, flower, or another shape.
- To ensure that students know when to use the different kinds of turns (point turn, single-motor turn, or curved turn), make an obstacle course that requires different turning methods (see illustration below and/or Appendix A). The students must write a program that makes the left wheel of the robot follow a path and parks the robot in the parking area.

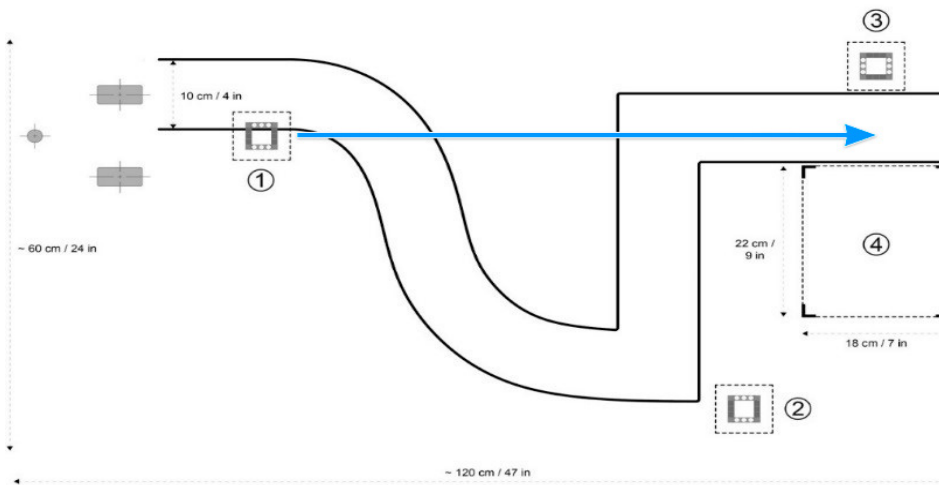

The obstacle course can be simplified for some students by allowing them not to drive through the curve. This will allow the robot to drive in a straight line and then park.

For this path, use curved turns for the first section, followed by single-motor turns for the 90-degree turns, and finally, a point turn before reversing the robot into the parking area.

### Discussion Questions

**Robot Behavior:** What did you discover when using the different turn methods?

- *The Steering Parameter Value was set to 50 to perform a single motor turn, and the Steering Parameter Value was set to 100 or -100 to perform a point turn.*

**Program Flow:** What is the purpose of the Wait Block?

- *The Wait Block makes your program wait for something before continuing to the next block in the sequence. You can wait for a certain amount of time for a sensor to reach a certain value, or for a sensor value to change.*

**Discovery:** Which method of turning worked the best for the curved line?

- *Move Tank or Move Steering Blocks work best because they keep both motors running in the same direction, with one motor running slightly slower.*

### Assessment

During the lesson, students can interact with the Introduction to Robotics rubrics, using peer or self-assessment by marking the box that best reflects their level of work. Help your students to improve by writing a comment for each of them in the Notes column during the lesson cycle.

## Lesson 3 – Move Object

### Objective

After completing this lesson, students will be able to program their robot to move and release objects of different shapes and sizes.

### Duration

2 to 3 x 45 mins.

### Preparation

Find several objects of different shapes and sizes that may or may not fit in the frame of the Medium Motor Module. For this Lesson Challenge you will need to prepare an obstacle course on the floor. You can use a large sheet of paper, markers, or sticky tape (see illustration below).

### Procedure

1. Students build and attach the Medium Motor Module to the Driving Base.
2. Students build the Cuboid.
3. Students complete the **Move Object** tutorial to understand how they can use the Medium Motor Module to grab the Cuboid.
4. In the “Test It” phase, the students will see a sample program to copy. Ensure that each group takes the time to describe the robot's behavior in their own words, while running the program. This encourages the students to reflect on what they see and how it relates to the programming blocks. Students can record notes on the Canvas by adding a Comment Box from the menu.

The following sample program is provided for the students:



Example of a robot behavior description:

Using the Medium Motor Module, the robot lowers the frame and grabs the Cuboid. It then reverses before raising the frame to release the Cuboid.

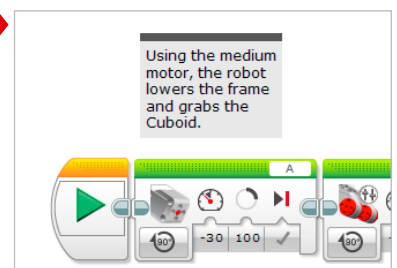
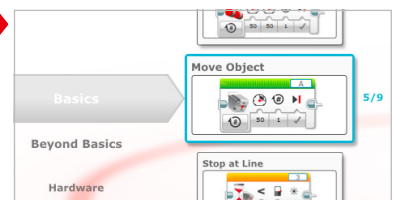
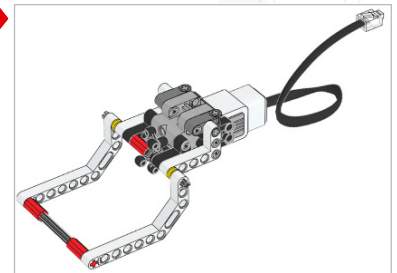
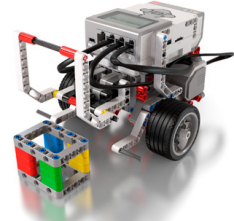

5. Students complete the “Modify It” task. The shape and size of different objects challenges students to modify their program or make changes to the Medium Motor Module to enable the robot to grab the different objects. When modifying the program, students will have to change the number of degrees the Medium Motor turns in order to accommodate the varying dimensions of the objects.

**Note:** Before modifying the Medium Motor Module, be aware that it is also required in Lesson 4 and Master Challenge 2.

6. Lesson Challenge:

Combine the optional challenge of Lesson 2 with moving the Cuboid (or another object) from predetermined start and end positions (see illustration below and/ or Appendix A). For an additional challenge, students can also use the Ultrasonic Sensor to help detect the Cuboid (see Lesson 4 for further details).

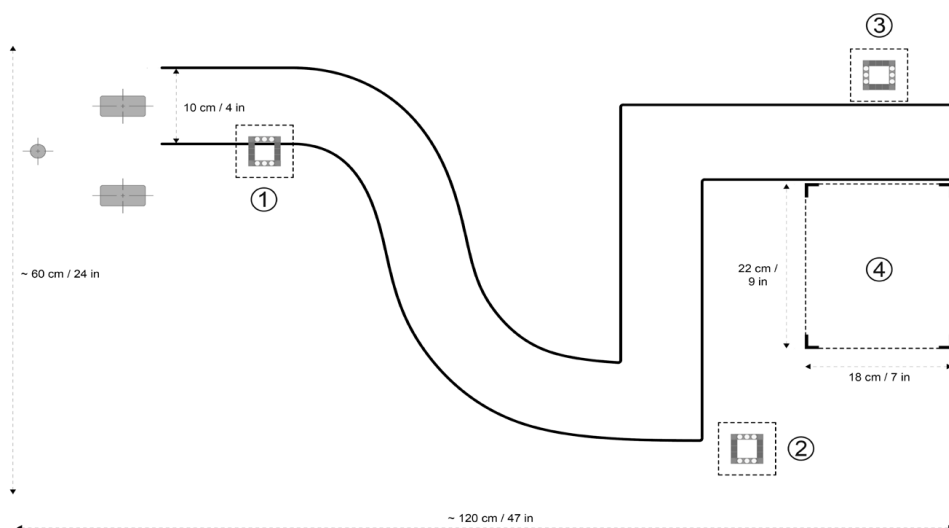

### Discussion Questions

**Robot Behavior:** How did you overcome the problem of moving larger sized objects?

- Modified the Medium Motor Module frame to fit the larger objects.

**Program Flow:** What did you have to change in order to move different sized objects?

- The number of degrees of the Medium Motor Block had to be changed.

**Discovery:** What did you discover when using the Medium Motor Module?

- In order for the robot to lower the Medium Motor Module, the Medium Motor Block Power setting must be set to a negative (-) value.

### Assessment

During the lesson, students can interact with the Introduction to Robotics rubrics, using peer or self-assessment by marking the box that best reflects their level of work. Help your students to improve by writing a comment for each of them in the Notes column during the lesson cycle.

## Lesson 4 – Stop at Object

### Objective

After completing this lesson, students will understand the difference between the Change and Compare Modes of the various EV3 sensors. This particular lesson features the Ultrasonic Sensor.

### Duration

2 to 3 x 45 mins.

### Preparation

Make sure you understand the difference between Change and Compare Modes. When using Compare Mode, the program waits for a certain distance to be read by the sensor. When using the Change Mode, the program reads the distance and then waits for a certain increase or decrease in distance. For this Lesson Challenge, you will need to prepare an obstacle course on the floor. You can use a large sheet of paper, markers, or sticky tape (see illustration below).

### Procedure

1. Students build the Ultrasonic Sensor Module and attach it to the Driving Base.
2. Students complete the **Stop at Object** tutorial, during which they learn that the Ultrasonic Sensor measures distance to objects. Understanding this allows students to program the robot to react to a detected object.
3. In the “Test It” phase, the students will see a sample program to copy. Ensure that each group takes the time to describe the robot’s behavior in their own words, while running the program. This encourages the students to reflect on what they see and how it relates to the programming blocks. Students can record notes on the Canvas by adding a Comment Box from the menu.

The following sample program is provided for the students:



Example of a robot behavior description:

Measuring distance using the Ultrasonic Sensor, the robot moves forward until it detects a decrease of 11 cm from the Cuboid and stops. The robot then reverses until it detects an increase of 6 cm from the Cuboid.

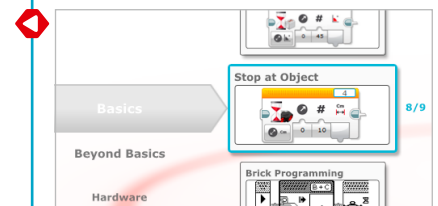



4. Students also complete the “Modify It” task. They should realize that the robot will always move forward 11 cm and then backwards 6 cm, regardless of the start distance to the Cuboid; this is the essence of the Ultrasonic Sensor’s Change Mode.
5. Lesson Challenge Ideas:  
Students attach the Medium Motor Module and grab the Cuboid (see illustration below and/or Appendix A). Remind students to use the Wait Block’s Ultrasonic Sensor in Compare Mode so that the robot moves close enough to the Cuboid. The following scenarios can be used:
- Cuboid in position 1 → robot in start position → make the robot move the Cuboid to position 2 and return to the start position
  - Cuboid in position 1 → robot in start position → make the robot move the Cuboid to position 3 and then park in position 4
  - Cuboid in position 3 → robot starts in position 4 → make the robot move the Cuboid to position 1 following the path

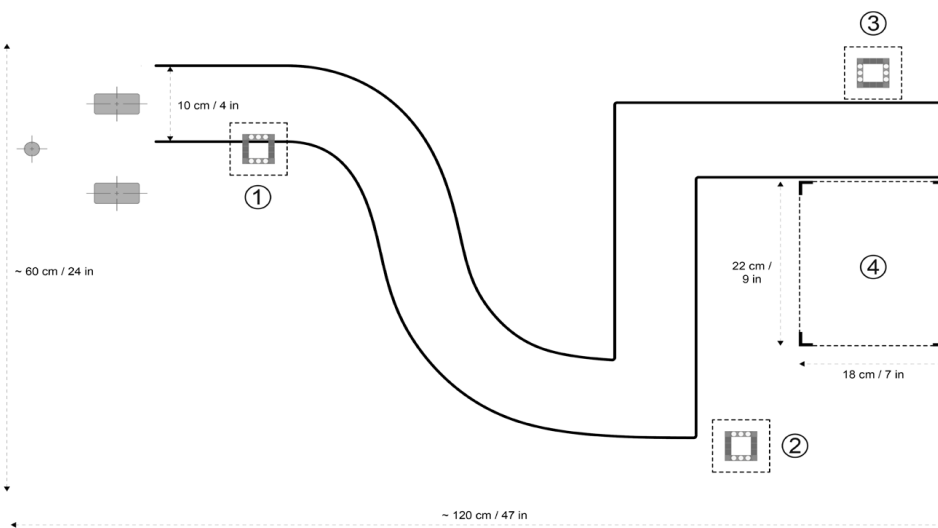

#### Change Mode:



#### Compare Mode:

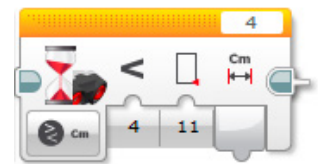

### Discussion Questions

**Robot Behavior:** What happens if the speed of the Medium Motor Module is set too high?

- *The Medium Motor Module knocks over or pushes aside the Cuboid before it can take hold of it.*

**Program Flow:** What is the difference between the Change and Compare Modes when using the Ultrasonic Sensor?

- *Change Mode reads the distance and then waits for an increase or decrease. Compare Mode waits for a certain predefined distance.*

**Discovery:** What happens to the robot when it drives towards a round object?

- *The Ultrasonic Sensor does not always recognize the shape, as it is unable to receive a signal back.*

### Assessment

During the lesson, students can interact with the Introduction to Robotics rubrics, using peer or self-assessment and can record their progress by marking the box that best reflects their level of work. Help your students to improve by writing a comment for each of them in the Notes column during the lesson cycle.

## Lesson 5 – Stop at Angle

### Objective

After completing this lesson, students will be able to turn their robot based on input from the Gyro Sensor.

### Duration

2 to 3 x 45 mins.

### Preparation

Familiarize yourself with the Gyro Sensor to ensure that you can detect when it is drifting and how to correct it. The Gyro Sensor chapter in the User Guide will help familiarize you with the sensor. This topic is also covered in Step 4 of the procedure below. Using sticky tape and protractors, students can create different angles on the floor to validate the turning angle of their robot. For tasks 5a and 5b, you will need to provide rubber bands to allow the students to attach a pen to their robot. For task 5c, you will need to prepare a maze on the floor. You can use a large sheet of paper, objects, markers, or sticky tape (see illustration below).

### Procedure

1. The students build the Gyro Sensor Module and attach it to the Driving Base.
2. The students complete the **Stop at Angle** tutorial to make the robot turn 45 degrees based on Gyro Sensor angle readings.
3. In the “Test It” phase, the students will see a sample program to copy. Ensure that each group takes the time to describe the robot’s behavior in their own words, while running the program. This encourages the students to reflect on what they see and how it relates to the programming blocks. Students can record notes on the Canvas by adding a Comment Box from the menu.

The following sample program is provided for the students:



Example of a robot behavior description:

Measuring rotational angle using the Gyro Sensor, the robot point turns until it detects an angle increase of 45 degrees. The robot then drives forward for one rotation and stops.



4. Troubleshooting: The troubleshooting notes included in the tutorial will help students understand how to avoid Gyro Sensor drift. Introduce the EV3 Brick Port View App as a method of checking the sensor reading. As the Gyro Sensor has a tolerance of +/- 3 degrees, you should therefore expect to compensate for that in the programs (e.g. to make a 90-degree turn, you may have to set the Threshold Value parameter of the Wait Block's Gyro Sensor – Change – Angle Mode to 87 degrees).



5. In the “Modify It” task, you may want to introduce students to the Loop Block as a way of decreasing the number of blocks needed to drive in a square. However, allow the students sufficient time to work it out for themselves.

Suggested program:

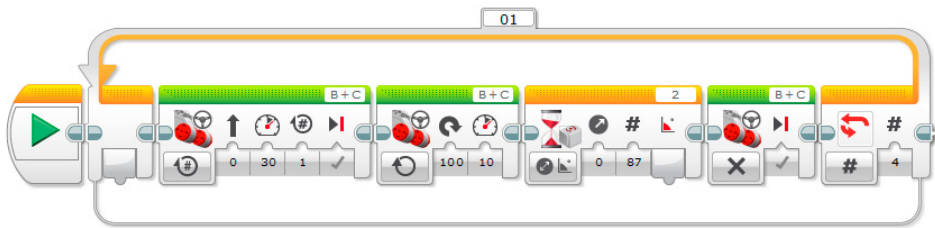

## 6. Lesson Challenge Ideas:

- Attach a pen to the robot, then use a Gyro Sensor to program your robot to draw the letter "Z."
- Attach a pen to the robot, then use a Gyro Sensor to program your robot to draw a star shape (consisting of five identical angles). Next, try increasing or decreasing the angle. How does the shape change?
- Challenge students to make their robot navigate through a maze using the Gyro Sensor (see illustration below and/or Appendix B).

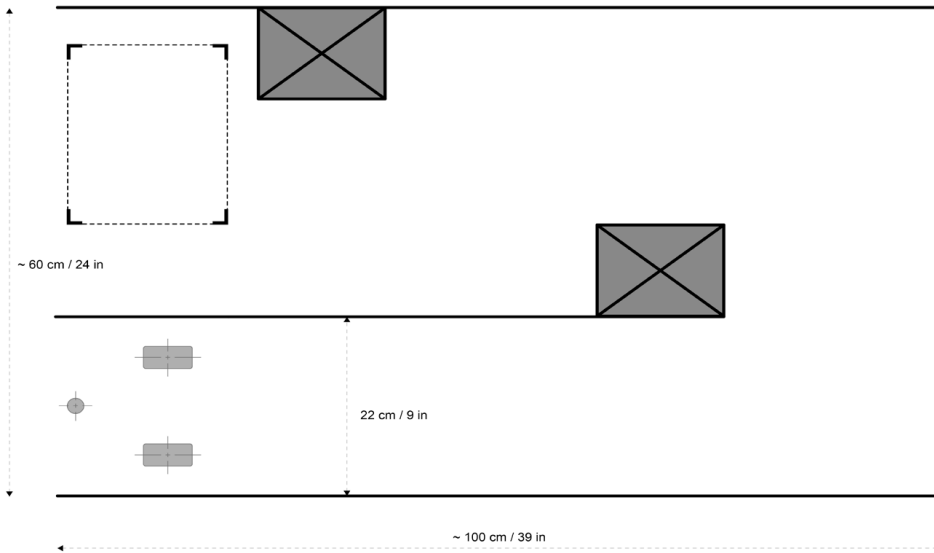
**Discussion Questions**

**Robot Behavior:** What did you have to do in order to make your robot turn 90 degrees?

- *Slow down the rotation speed of the robot and potentially set the angle to a value lower than 90 degrees.*

**Program Flow:** Why is it important to know how to set the Threshold Value?

- *This can make the difference between whether or not the robot reacts to the input of the sensor. It is also a way in which the robot can be 'fine-tuned' to make it more accurate.*

**Discovery:** What did you find was the difference between the Change and Compare Modes?

- *Change Mode - Wait for the selected value to change.*
- *Compare Mode - Wait to reach a selected value.*

**Assessment**

During the lesson, students can interact with the Introduction to Robotics rubrics, using peer or self-assessment and can record their progress by marking the box that best reflects their level of work. Help your students to improve by writing a comment for each of them in the Notes column during the lesson cycle.

## Lesson 6 – Stop at Line

### Objective

After completing this lesson, students will be able to use the Color Sensor to stop the robot when a line is detected. Students will also be able to set a Threshold Value for a sensor.

### Duration

2 to 3 x 45 mins.

### Preparation

Provide the students with different colored paper or sticky tape, and a sheet of white paper with a thick black line printed across it. Follow these steps to test whether the Color Sensor can read the selected color materials correctly:

1. Turn on the EV3 Brick and connect a Color Sensor to Port 3.
2. Navigate to the Port View App and open it.
3. Use the Right Button to navigate to Port 3.
4. The value shown is the Reflected Light Intensity (COL-REFLECT). Press the Center Button to change the mode.
5. Scroll down the displayed list, select Color Mode (COL-COLOR) and then point the sensor at the colored material. The value displayed equates to the following colors: 0, No Color; 1, Black; 2, Blue; 3, Green; 4, Yellow; 5, Red; 6, White; and 7, Brown.
6. If the value does not match the color of your material, you will need to use another material.

**Note:** For best accuracy when in Color Mode or Reflected Light Intensity Mode, the sensor must be held perpendicular and close to, but not touching the surface being detected.

### Procedure

1. Students build the Color Sensor Down Module and attach it to the Driving Base.
2. Students complete the **Stop at Line** tutorial to detect a black line using the Color Sensor.
3. Students read and practice setting the Threshold Value to enable the best results from the Color Sensor. They can do this by clicking on the link on page 4 of the “Test It” page.

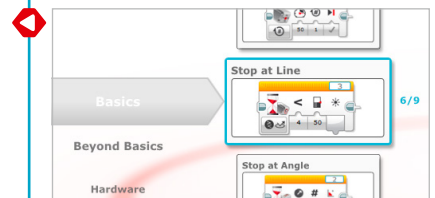
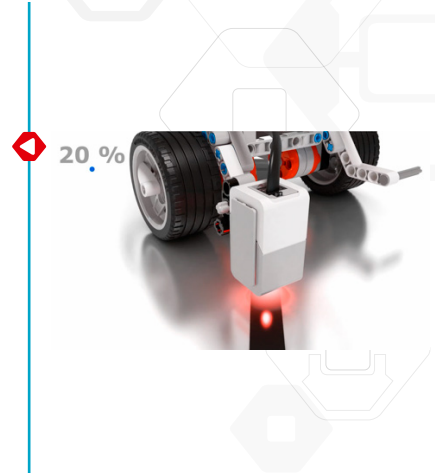

- In the “Test It” phase, the students will see a sample program to copy. Ensure that each group takes the time to describe the robot’s behavior in their own words, while running the program. This encourages the students to reflect on what they see and how it relates to the programming blocks. Students can record notes on the canvas by adding a Comment Box from the menu.

The following sample program is provided for the students:



Example of a robot behavior description:

Measuring the Reflected Light-Intensity using the Color Sensor, the robot turns until it detects the black line and then stops.

- Students complete the “Modify It” task, in which they practice detecting lines that are lighter colored.
- Lesson Challenge:  
Ask the students to change the mode of the Color Sensor to Color Mode and see if they can get the robot to stop on a blue line.

The following sample program is provided for the teacher:

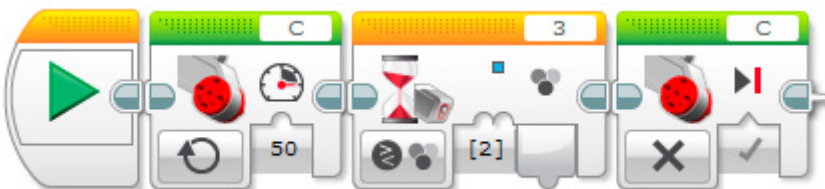

Example of a robot behavior description:

Measuring color using the Color Sensor, the robot turns until it detects the color blue and then stops.

Ask the students to find out what the No Color parameter does (it causes the robot to react when the Color Sensor fails to detect a color that matches any of the predefined colors).

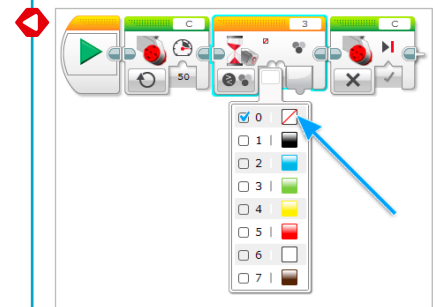

### Discussion Questions

**Robot Behavior:** Which color or shade reflects the most light?

- *White reflects the most and black reflects the least.*

**Program Flow:** Was it easier to set up the Wait Block for measuring Color or Reflected Light Intensity?

- *When detecting a color, the color is just selected. When reacting to reflected light, a good threshold value must be found in order for the robot to behave as expected. Color is easier if the Color Sensor recognizes the color.*

**Discovery:** What would you do if the robot were to detect a gray color?

- *Use the Wait Block set to read the Color Sensor in Reflected Light Intensity Mode.*

### Assessment

During the lesson, students can interact with the Introduction to Robotics rubrics, using peer or self-assessment and can record their progress by marking the box that best reflects their level of work. Help your students to improve by writing a comment for each of them in the Notes column during the lesson cycle.

## Lesson 7 – Switch

### Objective

After completing this lesson, students will be able to use the Switch Block to make dynamic sensor-based decisions in order to make their robot follow a line.

### Duration

2 to 3 x 45 mins.

### Preparation

Provide students with black and gray sticky tape to make a path for the robot to follow.

### Procedure

1. If not already built, students build the Color Sensor Down Module and attach it to the Driving Base, pointing down.
2. Students complete the **Switch** tutorial. Even though the Wait Block can be used to make a robot follow a line, this tutorial uses the Switch Block in order to introduce the abstract concept of if/then statements to the students.
3. In the “Test It” phase, the students will see a sample program to copy. Ensure that each group takes the time to describe the robot’s behavior in their own words, while running the program. This encourages the students to reflect on what they see and how it relates to the programming blocks. Students can record notes on the Canvas by adding a Comment Box from the menu.

The following sample program is provided for the students:

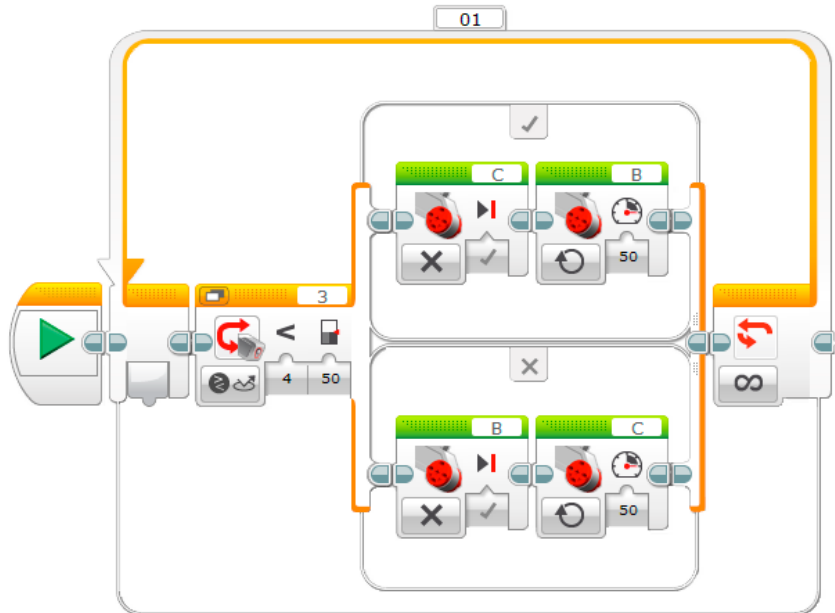

Example of a robot behavior description:

Moving forward along a line, the robot uses the Color Sensor to alternately switch each motor on and off when it detects changes in brightness reflected by the dark line and bright surface. This is why the robot “wiggles” forward.

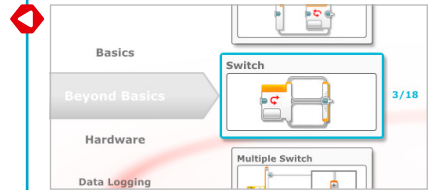
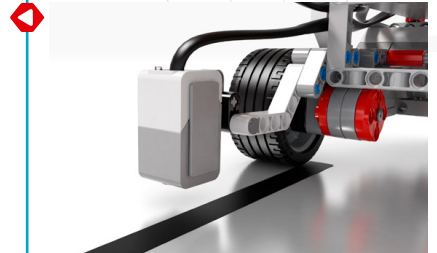



4. Students complete the “Modify It” task, which allows them to test their program with a lighter-colored line. This will challenge them to experiment with the Wait Block’s Threshold Value parameter.
5. Lesson Challenge Ideas:
  - a. Ask the students to test how fast they can make their robot follow a line.
  - b. Make a line-follower program that uses Move Steering Blocks to perform curved turns rather than the sharp single-motor turns used in the tutorial.
  - c. The tutorial sample program uses a Switch Block to create a line follower. Can they produce the same result without using a Switch Block?

### Discussion Questions

**Robot Behavior:** What did you have to do in order to make the robot follow the line more smoothly?

- *Keep both motors running, one at a lower speed than the other, or use the Move Steering Blocks.*

**Program Flow:** What is a threshold value?

- *The threshold value is the average number reading between light and dark. This is the number that you add to the Switch Block.*

**Discovery:** What did you have to do in order for the robot to follow a gray line?

- *Work out the average threshold value between white and gray.*

### Assessment

During the lesson, students can interact with the Introduction to Robotics rubrics, using peer or self-assessment and can record their progress by marking the box that best reflects their level of work. Help your students to improve by writing a comment for each of them in the Notes column during the lesson cycle.

## Master Challenge 1 – The Turntable Challenge

### Objective

The objective of this Master Challenge is for the students to navigate their robot around a four-bay, turntable-style parking area using a combination of point turns and sensors. After completing this Challenge, students will be able to use angles to predict the final position of their robot and compensate for factors that may affect the accuracy of the Gyro and Color Sensors.

### Prerequisites

At a minimum, students must be familiar with the Color Sensor and Gyro Sensor, as featured in the **Stop at Line** and **Stop at Angle** Lessons.

### Duration

2 to 4 x 45 mins.

### Preparation

To create the Challenge mat illustrated below and/or in Appendix C, the students will need protractors, long rulers, pencils, markers, and blue sticky tape or blue paper.

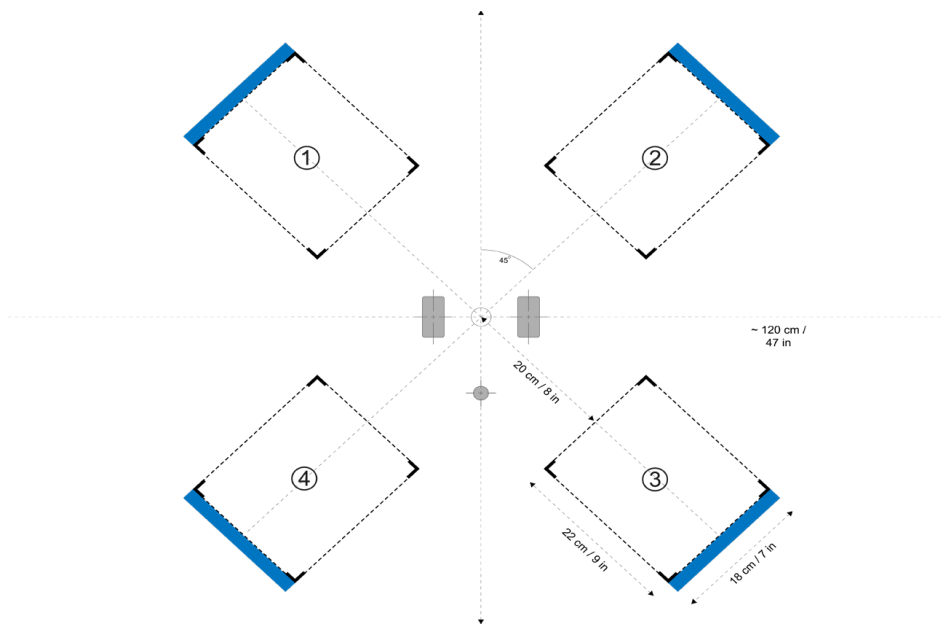

### Tasks

- Using two sensors, students move the robot from the center to final positions 1, 2, 3, and 4. If using the suggested angles for the Wait Block's Gyro Sensor Mode, students should create their own copy of the chart below and try to predict which of the parking bays their robot will drive into:

Programmed Angle	Predicted Parking Bay	Actual Parking Bay
45 degrees clockwise		
135 degrees counterclockwise		
405 degrees counterclockwise		
		3

**Note:** There may be several correct answers, as the robot can be rotated both clockwise and counterclockwise.

- Create a program that uses a Switch Block to enable students to navigate the robot into one of the four parking bays by pressing one of the EV3 Brick Buttons.

The following sample program is provided for the students:

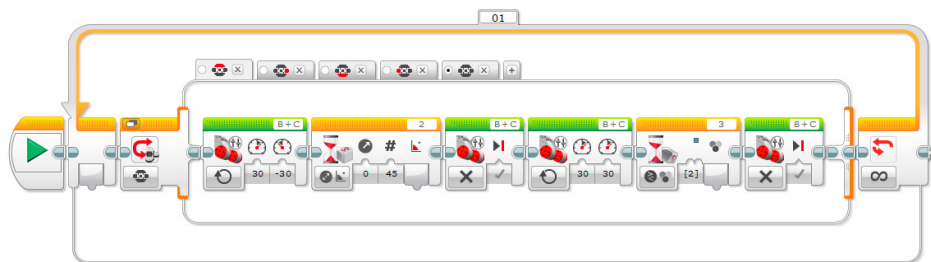

### Assessment

Observe and/or ask questions to determine if the students:

- Use both the Color and Gyro Sensors
- Correctly predict the angle required to park the robot in each of the parking bays
- Use the blue line to stop forward movement
- Can compensate for the factors that may affect the stopping precision when using the Gyro Sensor (sensor tolerance, motor slack, and rotational momentum)
- Work cooperatively to solve the tasks

During the lesson, students can interact with the Introduction to Robotics rubrics, using peer or self-assessment and can record their progress by marking the box that best reflects their level of work. Help your students to improve by writing a comment for each of them in the Notes column during the lesson cycle.

## Master Challenge 2 – The LEGO® Factory Robot Challenge

### Objective

The purpose of this Master Challenge is to create a simplified representation of one of the real-life robots used in LEGO® factories around the world to automate various tasks. After completing this Challenge, students will be able to combine what they have learned in the previous lessons to master the basics of robotics.

### Prerequisites

It is recommended that students complete all seven lessons before beginning this Master Challenge. However, if you prefer a more project-based, explorative method, you can start out with this challenge and allow students to find help on their own by referring to the lessons.

### Duration

2 to 6 x 45 mins.

### Preparation

To create the path illustrated below and/or in Appendix D, the students will need sticky tape, markers, measuring tape, the Cuboid, and a large object at the end of the black line. Students might also need a large protractor for measuring the angle in step three below.

### Tasks

1. Detect and grab the Cuboid using the Medium Motor and Ultrasonic Sensor Modules.
2. Drive the robot forward exactly 84 cm.
3. Determine and turn  $x$  degrees clockwise using the Gyro Sensor to point the robot towards the target circle.
4. Drive as close as possible to the center of the target and release the Cuboid.



5. Locate the line using the Color Sensor. To challenge students, use sticky tape of a different color than what was used in the **Stop at Line** and **Switch** lessons.
6. Have the robot follow the line towards the large object.
7. Stop right in front of the object. Here, the main challenge for the students is to define for how long the robot should follow the line before stopping. The large object at the end of the line gives students a chance to escape the line-follower loop using the Ultrasonic Sensor, which can also be used to solve the Challenge.

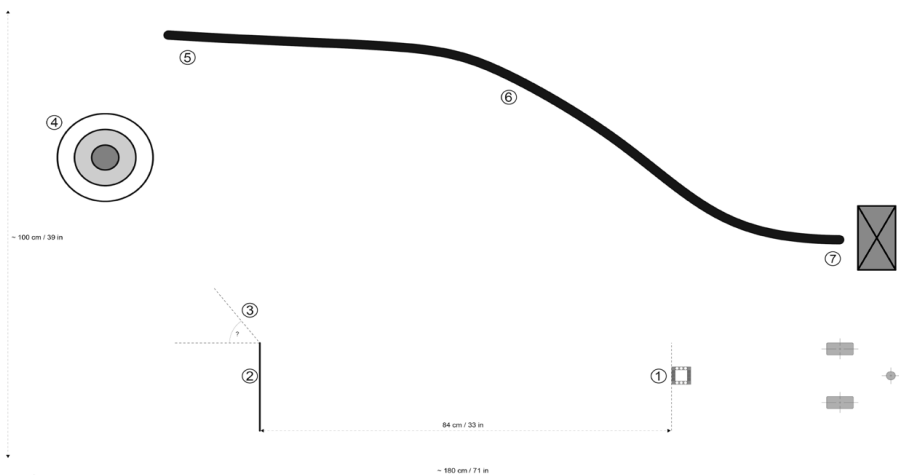

### Assessment

Observe and/or ask questions to determine if the students can use their experience from the seven lessons to solve this seven-step Challenge by:

- Understanding the difference between Change and Compare Modes; they should use the Wait Block's Ultrasonic Sensor in Compare Mode to achieve the best results in this Challenge
- Calculating distance based on wheel circumference or using trial and error to get to the required 84 cm
- Estimating the turn angle by using a protractor and the Gyro Sensor
- Measuring the distance and then calculating the number of motor rotations to get close to the center of the target
- Programming the robot to stop at the line
- Following the line back
- Stopping in front of the large object
- Working cooperatively to solve the tasks

During the lesson, students can interact with the Introduction to Robotics rubrics, using peer or self-assessment and can record their progress by marking the box that best reflects their level of work. Help your students to improve by writing a comment for each of them in the Notes column during the lesson cycle.

## Design Brief Challenges

Not all robots are Driving Bases. These Design Brief Challenges test the students' ability to build and program their own creations based on a brief that allows for a diversity of solutions. Students have a chance to choose an approach that, compared to the step-by-step tutorials, is more open-ended. Design Brief Challenges also allow you to assess a student's creative and collaborative skills.

Four design briefs are listed below. For each Challenge, you should consider up front how many lessons the students are given in order to complete it. If the students are told that they have four 45-minute lessons and must then be ready to present their unique solution, they have a better chance of managing their time successfully, and can adjust their ambitions accordingly.

These Design Brief Challenges can be used as a starting point in your class; students can use the tutorials and help text as a reference.

### **Alarm System**

Build and program an alarm system using one or more sensors.

### **Dancing Robot**

Build and program a robot with attitude that moves to your favorite music.

### **Greeting Robot**

Build and program a robot that greets you positively when meeting it.

### **Robotic Sweeper**

Build and program a robot that sweeps objects out of its path.

## Relevant Standards

The seven lessons, two Master Challenges, and Design Brief Challenges provide a full introduction to robotics and are great examples of how to use robotics in a STEM context. Using the LEGO® MINDSTORMS® Education EV3 concept in the classroom opens up a range of valuable learning outcomes. Skills such as teamwork, creativity, and problem solving are an inherent part of the experience, and students' natural mastery of tablet devices will help them learn the language of programming more rapidly.

Below is a selected overview of standards addressed or partially addressed when using LEGO MINDSTORMS Education EV3. This list will grow steadily when you expand the use of EV3 in the classroom.

### Next Generation Science Standards

#### *Practices*

- Asking questions
- Developing and using models
- Planning and carrying out investigations
- Analyzing and interpreting data
- Using mathematics and computational thinking
- Constructing explanations and designing solutions
- Engaging in argument from evidence
- Obtaining, evaluating, and communicating information

#### *Crosscutting concepts*

- Cause and effect: Mechanism and explanation
- Structure and function
- Systems and system models

#### *Core Ideas: Engineering, Technology and Application of Science*

- Engineering Design
- Motion and stability: Forces and interactions
- Energy
- Waves and their applications in technologies for information transfer

**Computer Science Teachers Association***Computational Thinking*

- Recognize that software is created to control computer operations.
- Understand and use the basic steps in algorithmic problem solving.
- Develop a simple understanding of an algorithm.

*Collaboration*

- Work cooperatively and collaboratively with peers, teachers, and others using technology.
- Identify ways that teamwork and collaboration can support problem solving and innovation.

*Computing Practices and Programming*

- Use technology resources for problem solving and self-directed learning.
- Construct a program as a set of step-by-step instructions to be acted out.
- Implement problem solutions using a block-based visual programming language.

*Computers and Computing Devices*

- Use standard input and output devices to successfully operate computers and related technologies.
- Apply strategies for identifying simple hardware and software problems that may occur during use.
- Identify factors that distinguish humans from machines.
- Recognize that computers model intelligent behavior (as found in robotics, speech and language recognition, and computer animation).



**ISTE National Education Technology Standards***Creativity and Innovation*

- Students demonstrate creative thinking, construct knowledge, and develop innovative products and processes using technology.
- Apply existing knowledge to generate new ideas, products, or processes.
- Use models and simulations to explore complex systems and issues.

*Communication and Collaboration*

- Students use digital media and environments to communicate and work collaboratively, including at a distance, to support individual learning and contribute to the learning of others.
- Contribute to project teams to produce original works or solve problems.

*Critical Thinking, Problem Solving, and Decision Making*

- Students use critical thinking skills to plan and conduct research, manage projects, solve problems, and make informed decisions using appropriate digital tools and resources.
- Plan and manage activities to develop a solution or complete a project.
- Collect and analyze data to identify solutions and/or make informed decisions.
- Use multiple processes and diverse perspectives to explore alternative solutions.

*Digital Citizenship*

- Exhibit a positive attitude toward using technology that supports collaboration, learning, and productivity.
- Demonstrate personal responsibility for lifelong learning.

*Technology Operations and Concepts*

- Students demonstrate a sound understanding of technology concepts, systems, and operations.
- Understand and use technology systems.
- Select and use applications effectively and productively.
- Troubleshoot systems and applications.
- Transfer current knowledge to learning of new technologies.

**ITEEA Standards for Technological Literacy***The Nature of Technology*

- Students will develop an understanding of the characteristics and scope of technology.
- Students will develop an understanding of the core concepts of technology.

*Design*

- Students will develop an understanding of the attributes of design.
- Students will develop an understanding of engineering design.
- Students will develop an understanding of the role of troubleshooting, research and development, invention and innovation, and experimentation in problem solving.

*Abilities for a Technological World*

- Students will develop abilities to apply the design process.
- Students will develop abilities to use and maintain technological products and systems.

**Common Core Mathematics Standards***Practices*

- Make sense of problems and persevere in solving them.
- Reason abstractly and quantitatively.
- Construct viable arguments and critique the reasoning of others.
- Attend to precision.
- Look for and make use of structure.
- Look for and express regularity in repeated reasoning.
- Model with mathematics.
- Use appropriate tools strategically.

*Expressions and Equations*

- Solve real-life and mathematical problems using numerical and algebraic expressions and equations.

*Geometry*

- Solve real-life and mathematical problems involving angle measure, area, surface area, and volume.

**Common Core English Language Arts***Reading Standards for Literacy in Science and Technical Subjects*

- Follow precisely a multistep procedure when carrying out experiments, taking measurements, or performing technical tasks.
- Determine the meaning of symbols, key terms, and other domain-specific words and phrases as they are used in a specific scientific or technical context relevant to grades 6–8 texts and topics.

*Reading Standards for Informational Text*

- Draw on information from multiple print or digital sources, demonstrating the ability to locate an answer to a question quickly or to solve a problem efficiently.

*Speaking and Listening Standards*

- Engage effectively in a range of collaborative discussions (one-on-one, in groups, and teacher-led) with diverse partners on topics, texts, and issues, building on others' ideas and expressing their own clearly.

# Introduction to Robotics Class Assessment Record



Name	Class	Building and Setup	Curved Move	Move Object	Stop at Object	Stop at Angle	Stop at Line	Switch	Master Challenge 1	Master Challenge 2

